



**Midco**  
INTERNATIONAL



## Economite DS45B Gas Conversion Burner

The Economite Model DS45B direct spark ignition conversion burner is adaptable to most gas utilization equipment, including gravity and forced circulation furnaces and boilers, and is particularly recommended for horizontal and downdraft gas utilization equipment since it needs no draft to maintain a pilot. Power burner design makes it perfectly suited for oil burner replacement.

**In the United States,** installation must conform with local codes or, in the absence of local codes, with **Installation of Domestic Gas Conversion Burners, ANSI Z21.8a**-latest edition and **National Fuel Gas Code, ANSI Z223.1**-latest edition(s) available from American National Standard Institute. Further reference should be made to the recommendation of your fuel supplier.

**Note:** Any additions, changes or conversions required in order for the gas utilization equipment to satisfactorily meet the application needs must be made by a MIDCO distributor (or other qualified agency) using factory specified and approved parts.

**In Canada,** installation must conform with local codes or, in the absence of local codes, with **Installation Codes for Gas Burning Appliances and Equipment, CGA Standard CAN/CGA 1-B149.1 or 2**. When the conversion burner is used on Forced Air Central Furnace, the two yellow and black warning labels in the literature envelope shall be attached in accordance with **Installation Code, CGA Standard CAN/CGA 1-B149, Clause 5.4.4.4**. Further reference should be made to the recommendation of your fuel supplier.

**INSTALLER:** Inform and demonstrate to the user the correct operation and maintenance of this gas utilization equipment. Inform the user of the hazards of storing flammable liquids and vapors in the vicinity of this gas utilization equipment and remove such hazards. Affix this manual adjacent to the conversion burner. **CODE COMPLIANCE IS THE SOLE RESPONSIBILITY OF THE INSTALLER.**

**USER:** Retain this manual for future reference. If other than routine service or maintenance as described in this manual is required, contact a qualified service agency. **DO NOT ATTEMPT REPAIRS.** An inadvertent service error could result in a dangerous condition.

**SAFETY INFORMATION TERMS:** The following terms are used to identify hazards, safety precautions or special notations and have standard meanings throughout this manual. When you see the safety alert symbol and one of the safety information terms as shown below, be aware of the hazard potential.



**DANGER:** Identifies the most serious hazards which **will** result in severe personal injury or death.

**WARNING:** Signifies a hazard that **could** result in personal injury or death.

**CAUTION:** Identifies unsafe practices which would result in minor personal injury or product and property damage.

**WARNING:** If the information in these instructions is not followed exactly, a fire or explosion may result, causing property damage, personal injury or death.

**Do not store or use gasoline or other flammable vapors and liquids in the vicinity of this or any other appliance.**

### WHAT TO DO IF YOU SMELL GAS

- Do not try to light any appliance.
- Do not touch any electrical switch; do not use any phone in your building.
- Immediately call your gas supplier from a neighbor's phone. Follow the gas suppliers' instructions.
- If you cannot reach your gas supplier, call the fire department.

Installation and service must be performed by a qualified installer, service agency or the gas supplier.



**Midco International Inc.**

4140 West Victoria Street Chicago, Illinois 60646  
tel 773.604.8700 fax 773.604.4070

web [www.midco-intl.com](http://www.midco-intl.com) e-mail [sales@midco-intl.com](mailto:sales@midco-intl.com)

*Quality Designed for Proven Performance*



1207  
8470 72  
Printed in USA

# Part 1 Installation

## Specifications

SPECIFICATIONS NATURAL or PROPANE Gas	
AIR DELIVERY (Approximate Air Delivery at Zero Draft Draft).....	85 SCFM*
MAXIMUM FIRING RATE**.....	400 MBH***
MINIMUM FIRING RATE**.....	200 MBH***
TUBE DIAMETER.....	4 inches
TUBE LENGTH.....	9 inches
MINIMUM COMBUSTION CHAMBER SIZE	
400 MBH.....	10" W X 16 1/2" L or 15" dia.
300 MBH.....	9" W x 14" L or 13" dia.
200 MBH.....	7" W x 11" L or 10" dia.
GAS PRESSURE REQUIRED	
NATURAL.....	5.0" to 14.0" W.C.
PROPANE.....	11.0" to 14.0" W.C.
STANDARD VOLTAGE.....	120 Volts.....60 Cycle
FLAME SAFETY.....	Direct Spark Ignition of Main Flame, Electronic Safety
MAIN AUTOMATIC VALVE.....	3 Function Redundant
* SCFM = Standard Cubic Feet/Minute	
** Ratings Based on 1000 BTU/cu. ft. NATURAL, 2500 BTU/cu. ft. PROPANE at Sea Level	
*** 1 MBH = 1,000 BTU/Hr. One gallon fuel oil =140MBH.	

Derate burner for altitudes over 2,000 feet by 4% for each 1,000 feet of additional elevation.

## Part 1 Installation

**IMPORTANT:** The *ECONOMITE DS45B* is not intended for outdoor installation and must be protected from excessive moisture. Provide adequate clearance for service and proper operation.

### I Ventilation

If the former automatic oil burner gave trouble-free operation, it is probable that the gas utilization equipment area has sufficient infiltration of air for combustion and dilution of flue gases. **Nevertheless, the area must be checked:**

- Open basement or utility areas of normal construction, without storm windows or tight doors, will generally allow sufficient air infiltration. However, if the gas utilization equipment is located in a tight or separate room, ventilation to an open area as described above will be required. Install two permanently open grills, each sized on the basis of one square inch free area per 1,000 BTU (but not less than 100 square inches) of the total input rating of all gas utilization equipment in the combined space. One grille should be located within 12 inches of the ceiling, the other within 12 inches of the floor.
- If the gas utilization equipment is located in an area of unusually tight construction, or if an exhaust fan, kitchen ventilation system, clothes dryer and/or fireplace is installed in the building, provision must be made for an outside air supply near the gas utilization equipment area. Install permanently open grills sized at not less than one square inch free area per 4,000 BTU of burner input. When ventilating through horizontal ducts, grills should be sized at not less than one square inch free area per 2,000 BTU of burner input. In any case, the minimum dimension of rectangular air ducts shall not be less than 3 inches.
- In Canada, for detailed ventilation requirements, refer to standard CAN 1-B149.1 or .2 and/or local codes.

### II Preparation of the Gas Utilization Equipment

- Clean the gas utilization equipment, combustion chamber, heat exchanger interior and flue connections. Remove all adhering tars, scale, dirt and soot. Inspect for actual leaks and/or potential leaks.
- Cement all joints, including those in the gas utilization equipment base and around door frames, to prevent leakage into or out of the combustion chamber.
- The access or firing door should open easily to relieve pressure. If positive latches exist, they should be modified to permit easy opening; a spring loaded door holder is recommended.
- On all boilers, make certain the pressure relief safety valve is in good operating condition.

### III Combustion Chamber

A combustion chamber liner is normally required to protect non-heat transfer surfaces and to provide a radiant bed for rapid heat transfer to the primary surfaces of the heat exchanger. In most cases an existing oil burner combustion chamber liner can be used, if in good condition.

## Part 1 Installation Continued

### III Combustion Chamber Continued

- In the case of wet base boilers, where the entire firing chamber is comprised of heat exchange surfaces and no chamber liner was provided for oil firing, a liner is usually not required for the ECONOMITE. However, a liner or target wall may be necessary if the firing chamber is unusually short, in order to avoid flame contact on the heat exchanger walls or flueways.
  - If a built up chamber liner is required, use 2300°F minimum insulating material.
  - The burner tube, or the stainless steel sleeve that is included with the burner, must be sealed air tight into the combustion chamber liner opening with refractory material as shown by Figures 1 and 2. The sleeve is preferred as it is designed to properly locate the end of the tube relative to the inside wall of the combustion chamber, and to permit burner removal without breaking the seal.
- NOTE:** In no case should the burner tube be allowed to extend into the chamber proper; it must be set flush to 1" short of the inside surface, because high combustion chamber temperatures will cause premature electrode deterioration.

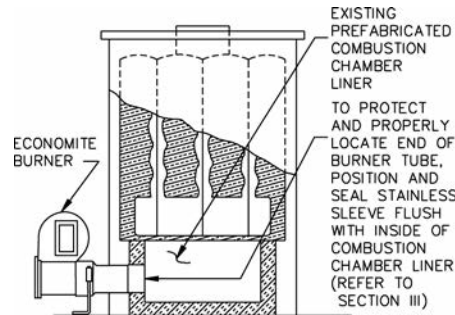

**Figure 1:** Dry Base Boiler with Combustion Chamber Liner (Warm Air Furnace Construction is Similar)

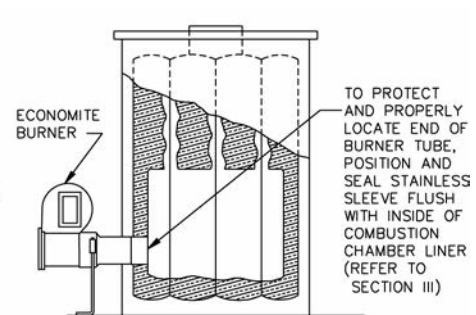

**Figure 2:** Wet Base Boiler with Unlined Combustion Chamber

- Special heat resistant alloy extension tubes and instructions are available for those applications where the burner tube is too short to reach the combustion chamber (such as old-fashioned gravity warm air furnace installations).

**⚠ WARNING: Burner cabinet must be mounted in orientation shown in Figures 1 and 2. Any other mountings may cause a dangerous condition, and will void burner warranty and agency approvals. Non-standard arrangements may be available for some models; consult factory for details if required.**

- Before permanently setting the burner in place, check that the venturi casting openings are free of foreign materials and the electrodes have not been damaged or displaced. See Figure 6.

### IV Chimney, Vent Connector\*, and Draft Control \*Formerly referred to as Flue Pipe

The chimney shall be inspected for unsafe conditions such as deteriorated masonry and excessive soot or other blockage or potential blockage.

- The Vent Connector shall be connected to a chimney already venting solid fuel burning equipment, an incinerator or an open fireplace.

□ The Vent Connector shall be made of non-combustible, corrosion resistant material capable of withstanding the vent gas temperature produced by the gas utilization equipment and of sufficient thickness to withstand physical damage.

- The Vent Connector shall be as short as possible. The entire length shall be readily accessible for inspection, cleaning and replacement.

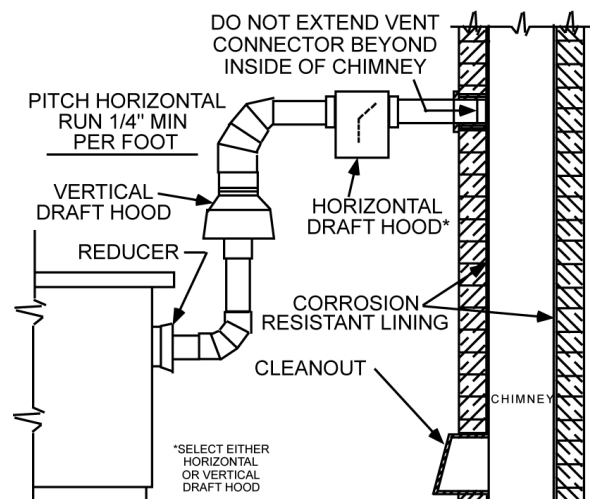

**Figure 3:** Draft Hood Positions

# Part 1 Installation

## Part 1 Installation Continued IV Chimney, Vent Connector\*, and Draft Control Continued

- The length of horizontal uninsulated Vent Connector between chimney and a single gas utilization equipment shall not exceed 75% of the height of the chimney above the connector, or 100% if the Vent Connector is insulated.
- The Vent Connector shall be installed so as to avoid turns or other construction features which create excessive resistance to flow of vent gas. It shall be installed without any dips or sags and shall slope upward at least 1/4" per foot.
- A manually operated damper shall **not** be placed in the Vent Connector or chimney of any gas utilization equipment.
- The Vent Connector shall be firmly attached to draft hood outlets and flue collars. Joints between sections of connector piping shall be fastened by sheet-metal screws or other approved means. The Vent Connector shall be supported for the design and weight of the material employed to maintain clearance and prevent physical damage and separation of joints.
- A draft hood or a barometric draft regulator shall be installed in the same room or enclosure as the equipment in such a manner as to prevent any difference in the pressure between the hood or regulator and the combustion air supply. In no case shall the relief opening of the draft hood or barometric draft regulator be located at a point lower than the top of the highest flue passage in the equipment.
- Gas utilization equipment requiring controlled draft may be equipped with a listed double acting barometric draft regulator, installed and adjusted in accordance with the manufacturer's instructions, **if approved by local codes.**
- A device which will automatically shut off gas to the burner in the event of sustained backdraft is required. It shall be of the listed manual reset type and installed and adjusted by a qualified service technician in accordance with the manufacturer's instructions.

Maximum Input	Flue Pipe Diameter
250 MBH	7"
320 MBH	8"
400 MBH	9"

**Table 1: Recommended Vent Connector Sizes**

## V Electrical

Installation wiring and grounding of the burner must conform to local codes, or, in their absence in the United States to **National Electric Code, ANSI/NFPA No. 70-** latest edition; in Canada, to **Canadian Electrical Code Part 1, CSA Standard C22.1.**

- Use copper wire not less than 14 gage for line voltage wiring. Be sure to hook up to permanently live circuit. Provide a fused on-off disconnect switch carrying a minimum 3 amp fuse.

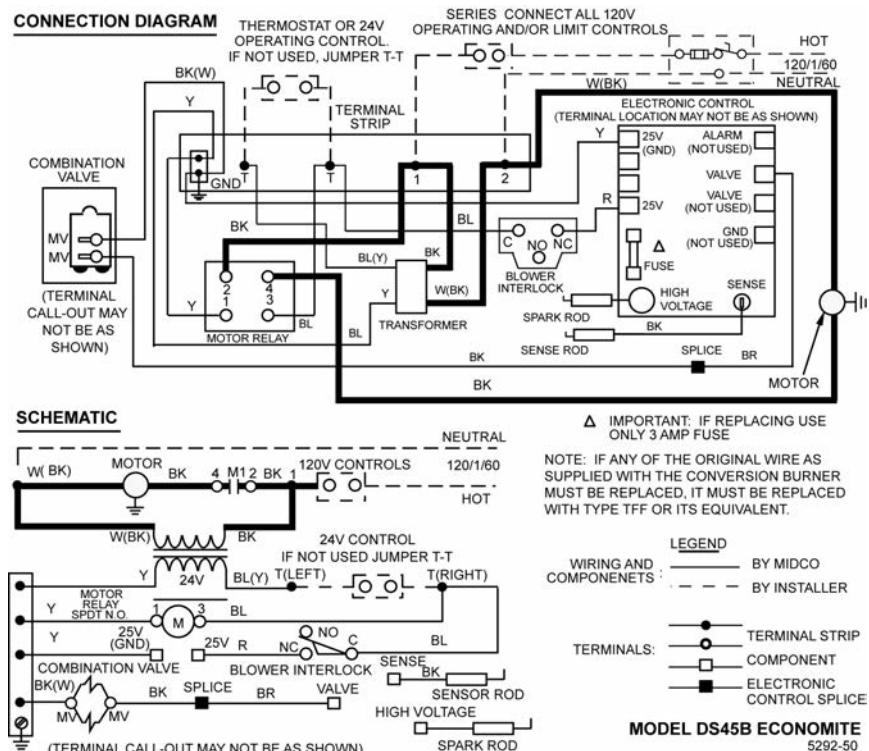

**Figure 4: Wiring Diagram**

## Part 1 Installation Continued

### V Electrical Continued

- The frame of the burner should be well grounded. Normally the piping and/or electric conduit will provide sufficient grounding. However, a terminal is provided on the terminal strip for positive grounding where insulated pipe couplings are used or where any doubt exists regarding grounding sufficiency.
- Confirm that the polarity is correct -- hot wire to strip terminal **1**, neutral **2** -- and that the neutral line is not subject to induced low voltage (check **2** to earth ground) from other equipment, as that can cause the electronic flame safeguard to malfunction.
- Each installation must include suitable limit control(s). Existing oil burner combination operating and limit controls are normally **NOT SUITABLE** for gas burner use.
- Set the thermostat heat anticipator for the total current draw handled by the thermostat. The current draw of the Economite 24V operating circuit is 0.7 amps.

**⚠ CAUTION: Label all wires prior to disconnection when servicing controls. Wiring errors can cause improper and dangerous operation. Verify proper operation after servicing.**

**⚠ CAUTION: Do not add any power consuming devices in the low voltage circuit as it could overload the transformer. Do not use the Motor Relay to operate any external devices as the extra load could damage the relay contacts.**

**NOTE:** If any of the original wiring as supplied with the conversion burner must be replaced, it must be replaced with type TFF wire or its equivalent.

### VI Piping

**⚠ CAUTION: The available gas pressure should be within the limits shown in SPECIFICATIONS section. Excessive pressure will damage Combination Valve and Regulator. If the supply pressure exceeds the 14.0" W.C. maximum, a suitable intermediate main regulator must be installed ahead of the Main Manual Shut-Off Valve shown in Figure 5.**

□ The burner gas supply piping should branch off from the main line as close to the gas meter as possible. Do not connect to the bottom of a horizontal section. Use new black pipe and malleable fittings free of cutting and threading burrs or defects.

□ Provide a sediment trap, union and 1/8" pressure tap in piping close to burner as shown in Figure 5.

□ Use pipe joint compound resistant to Liquid Petroleum Gases.

□ Piping must comply with local codes.

□ To obtain the maximum firing rate of 400 MBH, the NATURAL gas supply piping must be sized to provide a minimum of 5.0" W.C. pressure (11.0" W.C. PROPANE) to the inlet of the combination valve when the burner and all other gas utilization equipment are on.

**⚠ CAUTION: Because it is difficult to accurately control**

**pressure during supply pipe leak test, it is recommended that the Combination Valve be disconnected. Exposing the Combination Valve to a pressure over 1/2 PSIG will damage the valve and void its warranty.**

**⚠ DANGER: Explosion hazard. Do not use oxygen for pressure testing. An explosion could occur during initial start-up.**

□ If the burner piping must be rearranged because of space limitations, be sure to carry out the general arrangement shown in Figure 5. Install the combination valve in any position except up-side down.

□ When the burner is installed in jacketed equipment, it is recommended that the Combination Valve be left adjacent to the burner within the vestibule and the Main Manual Shut-Off Valve be installed outside.

Pipe Size	Type of Gas	Capacity - MBH			
		Length of Pipe			
		15	30	45	90
3/4	Propane	400	250	200	
	Natural	400	250	200	
1	Propane		400	350	250
	Natural		400	400	300
1 1/4	Propane			400	400
	Natural				
1 1/2	Natural				

Capacities shown are for a total pressure drop of 0.3" W.C. For 0.5" W.C. pressure drop, multiply capacity shown by 1.3. For higher permissible pressure drops, consult your fuel supplier.

**Table 2: Supply Pipe Capacities in MBH**

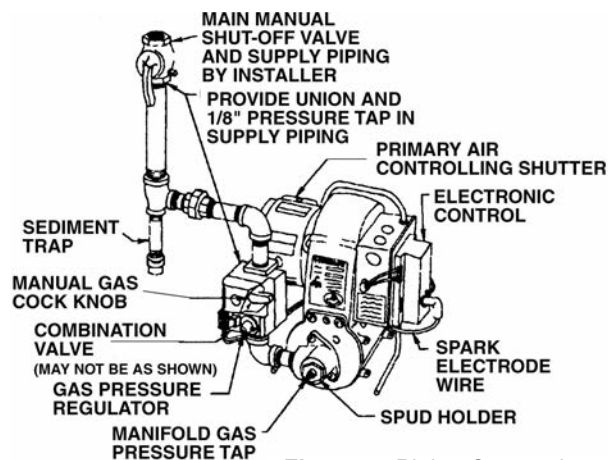

**Figure 5: Piping Connections**

# Part 1 Installation

## Part 1 Installation Continued VII Main Gas Spud

Standard burners are approved for use with NATURAL or PROPANE gas only, and should be used only with the gas specified on the rating plate.

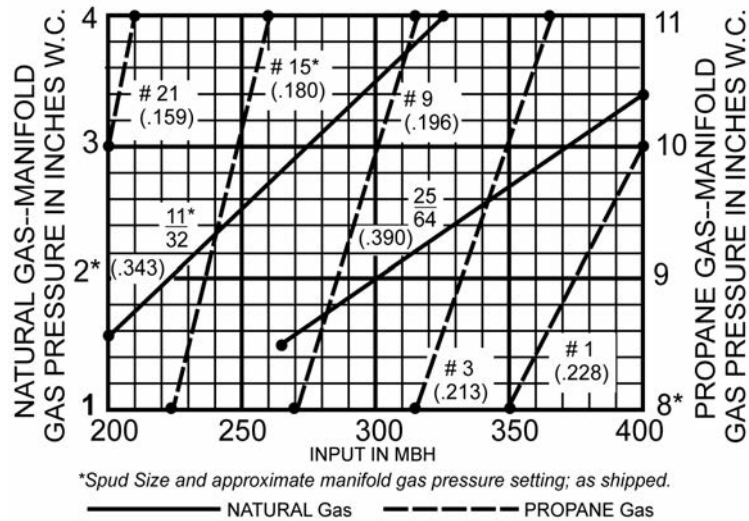

Table 3: Spud Capacity and Preliminary Gas Settings

- A standard Model DS45B ECONOMITE burner is shipped ready for NATURAL gas. As shipped, it is field convertible to PROPANE gas. See Below.
- A standard NATURAL gas Model DS45B burner is shipped with a .343 diameter orifice installed for an input capacity range of approximately 225 to 320 MBH. A second orifice with a .390 diameter orifice for an input capacity range of approximately 300 to 400 MBH is included in NATURAL SPUD KIT attached to burner (see Table 3).
- If a standard NATURAL gas Model DS45 is to be used with PROPANE gas, a conversion kit which contains 5 main orifice spuds, a PROPANE regulator head, a PROPANE label and instructions. Affix the PROPANE label over the NAT designation on the rating plate.
- If the required firing rate does not fall within the range of the installed spud, or if converting to PROPANE gas, select the correct input capacity range from Table 3 and install the spud with the correct orifice size (stamped with inch diameter) from the spud kit bag. If the required firing rate is at the minimum of a capacity range, select the next lower range spud.
- TO CHANGE MAIN SPUD: Turn Manual Gas Cock Knob on Combination Valve to **OFF**. Remove the Spud Holder. See Table 3 and Figure 5 or 8.
- The combination valve main gas pressure regulator is set to provide 2.0" W.C. NATURAL (8.0" W.C. PROPANE) manifold gas pressure for low to minimum capacity spud input. The burner is shipped with the primary air controlling shutter set **wide open** to provide a lean gas/air mixture during the initial start-up. Do not change the combination gas valve pressure regulator setting at this time.

**CAUTION:** The approximate air and gas settings described above are for initial start up only. Final settings must be made in accordance with Section VIII . Instructions for adjustment of the manifold gas pressure are detailed in Section XI .

## VII Initial Start Up/ Adjustment

**WARNING:** Ignition is automatic. Make spark observations into combustion chamber only with Main Manual Shut-Off Valve closed. Confirm that gas utilization equipment does not contain any accumulated gases. Purge as described in Step 3 below.

1. Check the burner piping and valves for gas leaks by applying a weak liquid soap solution to unions and joints with the gas supply on. Leakage will be indicated by the appearance of soap bubbles. Locate and correct all gas leaks before proceeding.

**WARNING:** DO NOT USE OPEN FLAME.

2. Purging the air from the gas supply line at this step will expedite the first light-off.

**IMPORTANT:** Purge outside the building.

Do not purge into the gas utilization equipment.

3. To purge the gas utilization equipment and chimney of any accumulated gases, turn Manual Gas Cock Knob on Combination Valve to **OFF**, turn burner power on, and set operating control to **ON** or thermostat to call for heat. Let the blower run long enough to accomplish four air changes, but not less than five minutes.

*Part 1  
Installation  
Continued  
VIII Initial Start Up/  
Adjustment*

4. **IMPORTANT:** Make sure that the capacity range of the installed spud and the preliminary primary air shutter setting are suitable for capacity rating of the gas utilization equipment. Refer to Section VII and Table 3.
5. **RESET** the Electronic Control by setting the operating control to **OFF** or the thermostat below room temperature for at least 30 seconds. See Section XII .
6. Confirm that Main Manual Shut-Off Valve is open. Turn Manual Gas Cock Knob on Combination Valve to **ON**.
7. Turn operating control to **ON** or set thermostat above room temperature. Main flame should come on when the motor reaches operating speed. Whenever the burner fails to light during the 6-second ignition trial, or if the flame is lost during the burner run and is not re-established within 6 seconds, the Electronic Control will shut off the Combination Valve and **LOCK OUT** To **RESET** the Electronic Control for restart, de-energize the Electronic Control by setting the operating control to **OFF** or thermostat below room temperature for at least 30 seconds. If burner still fails to light, turn it off and repeat from step 5 above. Then, if necessary, refer to the **TROUBLE CHART** to isolate the problem.



**WARNING: Repeated unsuccessful attempts to light will result in accumulated gases in gas utilization equipment and chimney. To prevent these gases from reaching an explosive level, periodically purge the gas utilization equipment and chimney as described in step 3 above.**

8. To make a preliminary setting of the burner input, determine the manifold gas pressure required from Table 3 and adjust the combination valve main gas pressure regulator accordingly. See Section XI .
9. To determine the firing rate for NATURAL gas, accurately time test dial for the number of seconds for one revolution and use the following formula. All other gas utilization equipment must be off.

$$\frac{3600 \times \text{test dial size} \times \text{BTU value}}{\text{No. of seconds for one rev. test dial.}} = \text{BTU/Hr.}$$

Then Divide by 1,000 for MBH value.

$$\text{Example: } \frac{3600 \times 1 \times 1000}{20} = 180,000 \text{ BTU/Hr.} = 180 \text{ MBH}$$

For PROPANE gas, consult your supplier for method of determining firing rate

10. Readjust the primary air shutter to provide a quiet, soft blue flame with well defined orange and yellow tips for NATURAL gas or with well defined yellow tips for PROPANE gas.
11. Check the operation of the burner; start and stop it several times with the thermostat or operating control.
12. With the burner running, check the operation of all limit and associated controls.
13. **PERFORM THE FOLLOWING FINAL ADJUSTMENTS** for combustion and flue gas temperature. Take the flue gas samples and temperature immediately ahead of the draft control.
  - A. The flue gas temperature should be above 325°F but not exceeding 550°F. Excessive flue gas temperatures will result in low efficiencies. Low flue gas temperature may cause excessive condensation. Reset gas input if necessary to adjust stack temperature.
  - B. Make the final setting of the primary air shutter by checking the flue gases with an **ORSAT** or similar combustion testing instrument. The carbon monoxide content should conform to local codes, or, in their absence to the level specified in the United States or Canadian Standard referenced on the front cover of this manual; and the carbon dioxide content should be approximately 9.5% for NATURAL and 12.1% for PROPANE, or within the limits prescribed by local codes.
14. Check the draft control to make sure there is no spillage of flue products into the room.
15. **FILL OUT THE INSTALLATION ADJUSTMENT DATA TAG** and affix to the burner or gas utilization equipment.

**NOTE:** For subsequent normal starting and shut off procedure, refer to **CONSUMER INSTRUCTIONS** or to the instruction plate mounted on the burner.

### X Venturi Casting and Electrodes

**⚠ DANGER:** Be sure that the Main Manual Shut-off Valve, Combination Valve and Burner Power Switch are turned OFF before removing any parts for service.

- The venturi casting and electrodes are part of the drawer assembly which can be removed as a unit. Remove the two back plate screws; then disconnect the elbow and pull out the drawer assembly.
- When servicing, clean venturi casting openings and electrodes. Inspect the wires and porcelain insulators carefully for hairline cracks which might provide an electrical leak path that could short out the ignition spark or flame signal.
- Examine the electrodes for any serious corrosion or loss of metal at the tip. The electrode assembly is not adjustable. If the electrodes have been bent out of position, or the spark gap is too wide (see Figure 6), the assembly is defective and must be replaced. Make sure that the wires go to the correct electrodes and that the rubber boots are in place.
- Make sure that the burner tube is properly positioned in the combustion chamber entry. It must be set 1" short of the inside face of the combustion chamber as shown in Figures 1, 2 or 8.

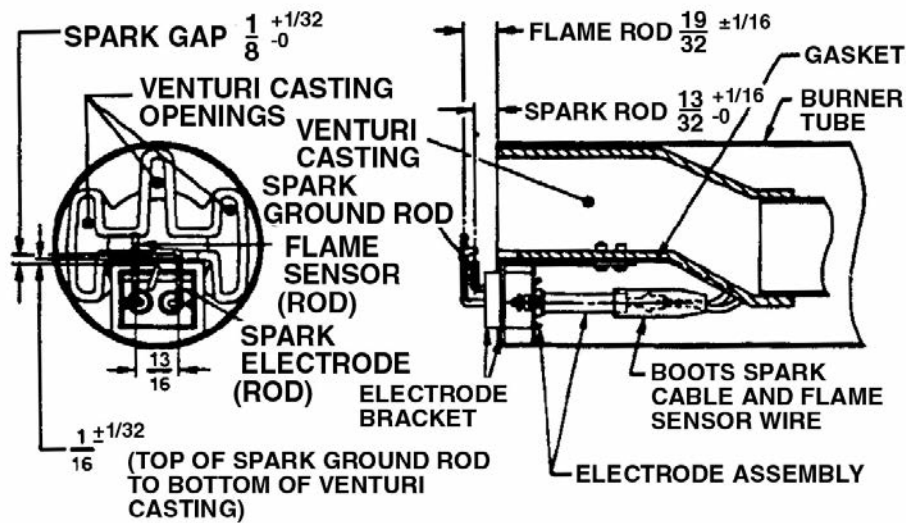

Figure 6: Venturi Casting and Electrode Assembly

### IX Blower Assembly

**NOTE:** BEFORE SERVICING, mark with a scribe line or measure opening of primary air controlling shutter, so that it can be reset to its original position following servicing.

- Cleaning of the blower wheel is usually the only service required. Need for cleaning is indicated if the air cage assembly shows an accumulation of dust and lint, or if the character of the flame indicates a deficiency of air. Motor cooling air vents should also be cleaned at this time.
- The blower side plate, motor and wheel are removed as an assembly. Disconnect the motor wires from terminal 2 on the burner terminal strip and 4 on the motor relay. Disconnect the motor conduit from the control box and remove the side plate screws.
- The blower wheel is equipped with a spring loaded centrifugal actuator to operate an electrical interlock switch so as to prevent the burner from firing if the blower wheel is not running at its operating speed. When the motor is off, the actuator spring forces the disk against the switch plunger to push it past its operating point. When running, the actuator pulls the disk clear of the plunger.
- To make a specific test of the interlock circuit:
  1. Turn burner power **OFF**.
  2. Turn Manual Gas Cock Knob on Combination Valve to **OFF**.
  3. Disconnect the motor wire from terminal 4 of the motor relay to keep the motor off.
  4. Turn burner power **ON** and set the operating control to **ON** or thermostat to call for heat. Check for 24V between the Electronic Control **25V** and **25V GND** terminals.



Part 2  
Service  
Continued  
IX Blower Assembly  
Continued

- A. No voltage: Interlock circuit OK.
  - B. Voltage present: check that switch bracket is screwed down tight (see Figure 7). If so, without disconnecting switch wires, remove switch bracket and manually depress switch plunger. If voltage is still present, or if the plunger has to be depressed to where dimension "A" of Figure 7 is less than 9/32" when switch clicks over, replace the switch.
5. If the switch tests OK, check dimension "A" of Figure 8 as follows:
- Switch plunger free.....9/32 to 11/32"
  - Disk free.....7/32 to 1/4"
  - Disk held all the way in.....15/32" min.
6. If plunger dimension is wrong, replace switch. If disk dimension is wrong, check that the actuator operates freely with a minimum movement of 1/4" from the free position. If movement is OK, reposition blower wheel on motor shaft. If not, replace wheel.

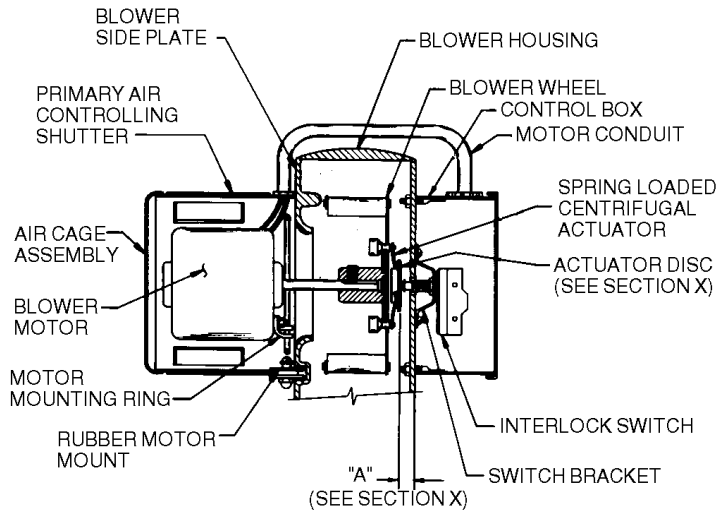

Figure 7: Motor, Blower Wheel and Interlock Assembly

XI Combination Gas Valve

The 24 volt combination valve serves three functions:

- 1) Manual Gas Shut-off, 2) Manifold gas pressure regulation, 3) Automatic electric redundant (double seated) gas valve.

□ For manual control the Manual Gas Cock Knob is turned full **ON** or full **OFF**. The dial has to be depressed to be turned in one direction, but it depends on the make of the valve whether it is to the **ON** or **OFF** position.

□ The main gas pressure regulator, which has an outlet pressure setting range of approximately 2.0" to 4.0" W.C., is factory set for a manifold gas pressure of 3.5" W.C. for NATURAL. If pressure adjustment is required for setting capacity, remove regulator cap for access to slotted adjustment screw. Turning of adjustment screw counter-clockwise reduces pressure; clockwise increases pressure. Do not adjust past the point where no change in pressure is noted.

**NOTE:** Pressure setting must be made with burner running and main gas **ON**.

**CAUTION:** When adjusting the regulator, if gas supply pressure is below its specified range, an overfire condition could result as pressure returns to normal, particularly if the regulator adjustment screw is bottomed out.

**ALWAYS** confirm that at least the minimum rated gas pressure is being supplied to the burner during regulator adjustments, and **NEVER** bottom out regulator screw.

□ To set to low outlet pressure for initial startup, turn the adjusting screw counter-clockwise 2.5 turns to raise it to about 1/4" below the top.

□ The tap for manifold gas pressure measurement is located in the burner spud holder (see Figure 5 or 8). Remove plug for access.

□ If the gas pressure regulator fails to maintain a constant manifold gas pressure within + 0.1" W.C., and it is confirmed that the inlet gas pressure to the combination valve is 14.0" W.C. maximum during standby, and 5.0" W.C. minimum for NATURAL gas (11.0" W.C. for PROPANE gas), with the main flame on, the regulator portion of the valve is defective and the entire valve must be replaced.

**Part 2  
Service  
Continued**  
**XI Combination Gas Valve  
Continued**

**XI Electronic  
Control System**

- If, on a call for heat, flame ignition does not occur, refer to the **trouble chart** for further information.
- If leakage through the valve occurs, as evidenced by the presence of flame on standby, the entire valve must be replaced.
- If the combination valve has been moved or replaced, soap bubble test for leaks with the burner running.

The Electronic Control is a 24 volt AC, solid state electronic device that automatically ignites and monitors the flame. It has an integral high voltage transformer and, upon a call for heat, applies high voltage to the spark electrode and 24V to the combination valve. When the flame is proven, the spark is terminated and the burner run continues.

- If the flame is not proven within 6 seconds, or if the proof of flame is lost during the burner run and not re-established within 6 seconds, the Control will shut off the combination valve and **lock out**. To **reset** the Electronic Control for restart, de-energize the Electronic Control by setting the operating control to **OFF** or thermostat below room temperature for at least 30 seconds.
- If the Electronic Control is changed, the replacement must be identical as to the make and model number, or must be an authorized substitute.

**⚠ WARNING: Explosion hazard.**  
**Do not use this device if it gets wet. It can malfunction and cause serious injury or death. Replace any device that has been wet.**

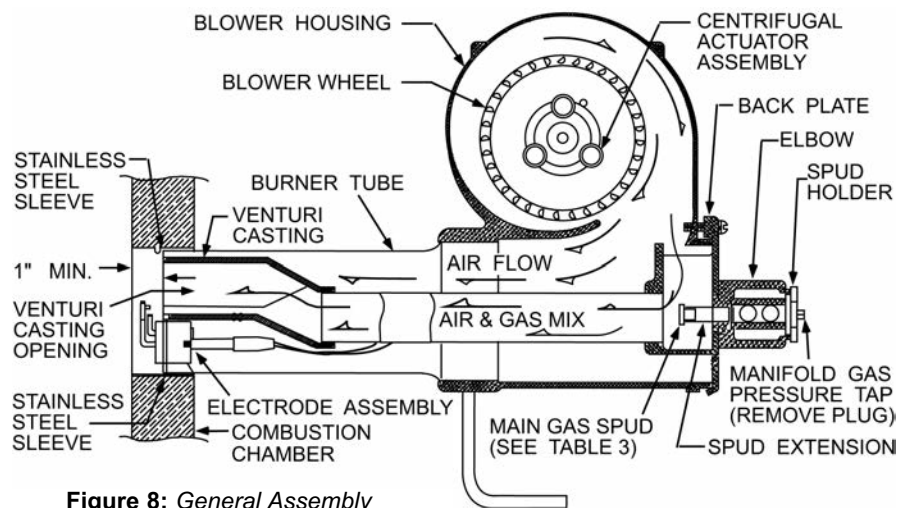

**Figure 8: General Assembly**

## Consumer Instruction

**Consumer Instruction  
Maintenance**

- Keep the area around the burner clear and free of combustible materials, gasoline or other flammable liquids or vapors. Do not obstruct burner air openings or ventilation grills for combustion air.
- The motor features permanently lubricated ball bearings and requires no routine oiling maintenance.

**IMPORTANT:** Check the burner flame periodically. A proper **NATURAL** gas flame will appear blue at the burner face with orange and yellow tips. A proper **PROPANE** gas flame will appear blue at the burner face with yellow tips. If the flame is too rich, it will appear billowy and yellow with hazy tips. If too lean, it will appear short and all blue. If the flame does not appear proper, **CONTACT A QUALIFIED SERVICE TECHNICIAN FOR CLEANING AND/OR READJUSTMENT.**

**⚠ WARNING:** If any flame is observed when the burner is on standby, or if the ignition spark or valve operator is heard to come on before the motor reaches operating speed, immediately turn off the manual gas control and burner power. A dangerous condition has developed and must be corrected. **CONTACT A QUALIFIED SERVICE TECHNICIAN FOR CLEANING, READJUSTMENT OR REPAIR.**

*Consumer Instruction  
Continued  
Maintenance Continued*

**LIGHTING INSTRUCTIONS:**

1. SET OPERATING CONTROL TO **OFF** OR THERMOSTAT BELOW ROOM TEMPERATURE.
2. TURN MANUAL GAS COCK KNOB ON COMBINATION VALVE TO ON
3. TURN BURNER POWER **ON**.
4. SET OPERATING CONTROL TO **ON** OR THERMOSTAT TO CALL FOR HEAT.
5. WAIT 6 SECONDS. IF BURNER HAS FAILED TO LIGHT, OR IF BURNER LIGHTS THEN GOES OUT AND SYSTEM GOES INTO SAFETY LOCKOUT, DE-ENERGIZE THE SYSTEM BY SETTING OPERATING CONTROL TO **OFF** OR THERMOSTAT BELOW ROOM TEMPERATURE FOR AT LEAST 30 SECONDS TO RESET THE SYSTEM AND THEN SET OPERATING CONTROL TO **ON** OR THERMOSTAT TO CALL FOR HEAT.

**TO SHUT OFF**

1. TURN MANUAL GAS COCK KNOB ON COMBINATION VALVE TO **OFF**.
2. TURN BURNER POWER **OFF**.

**SHOULD OVERHEATING OF THE GAS UTILIZATION EQUIPMENT OCCUR:**

1. Shut off the Main Manual Shut-off Valve to the equipment.
2. **Do not** shut off the power switch to the **ECONOMITE** burner, or to the equipment pump or blower.



**WARNING:** If PROPANE gas is used and the burner is located in a basement, crawl space or confining space, contact your gas supplier about installing a GAS LEAK warning device. PROPANE gas is heavier than air and can settle in low areas or confined spaces. This would create a danger of explosion or fire. If you suspect a gas leak, follow instructions on front of this manual.

## *Trouble Chart*

*Trouble Chart*

Make sure the thermostat and operating controls are calling for heat. Defective wiring or loose connections can simulate the component defects outlined below. Check associated wiring before replacing a component.

**ELECTRICAL AND FLAME CHECKS MUST BE MADE IN THE ORDER LISTED.**

- I. MOTOR WILL NOT RUN OR MOTOR RUNS IN REPEATED CYCLES.
  - A. Confirm 120V between strip terminals 1 and 2 and verify the circuit polarity and electrical ground, between strip terminal 1 and GND.
  - B. Check 24V\* operating control circuit:
    1. Between left strip terminal T and GND.
      - a. No voltage, transformer defective
      - b. Very low voltage,\* circuit overloaded or transformer defective.
    2. Between right strip terminal T and GND. No voltage, circuit between T and T is open.
  - C. Confirm 120V between strip terminal 2 and motor relay terminal 4:
    1. No voltage, motor relay is defective.
    2. Voltage present, motor is defective.
- II. MOTOR RUNS CONTINUOUSLY, BUT NO FLAME.
  - A. Confirm that both Main Manual Shut-Off and Combination Gas Shut-Off valves are in the ON position.
  - B. Whenever the burner fails to light during the 6-second ignition try, or if the flame is lost during the burner run and not re-established within 6 seconds, the Electronic Control will shut off the combination valve and lock out. To reset the Control for restart, set the operating control to OFF or thermostat below room temperature for at least 30 seconds.
    1. Check for 24V\* between the Interlock Switch NC terminal and strip terminal GND. No voltage, blower interlock circuit is defective. See Section X.
    2. If Electronic Control has a fuse, test for 24V\* from each end of fuse to strip terminal GND.
  - C. For each of the following tests, reset the Electronic Control per step II.B. TESTS ARE VALID ONLY DURING THE 6 SECOND TRIAL FOR IGNITION.
    1. TURN THE MANUAL GAS COCK VALVE OFF. Check for 24V\* between the Electronic Control VALVE terminal and strip terminal GND. No voltage, defective Electronic Control.

## Trouble Chart Continued

2. Check for 24V\* between valve TH (PWR) terminal and valve body:
    - a. With voltage, reset Electronic Control and listen for audible CLICK as first valve operator opens. No CLICK, replace valve.
  3. Check for ignition spark (spark length approximately 1/8"). Since this is a capacitor discharge system, observe closely when visually checking the spark as it is faint and thread-like and may be overlooked in bright light.
    - a. Between Electronic Control high voltage terminal and strip terminal GND. No spark, defective Electronic Control.
    - b. Between Electronic Control high voltage terminal and Spark Electrode Wire (insert head of #8x3/4" or longer round head screw into terminal wire). No spark, broken wire or cracked insulator, or "spark gap" too wide (see Section IX).
    - c. Between electrode tip and top of ground rod (see Figure 7). If electrode tip is not visible but spark can be heard continue with test II.C.4.
    - d. If spark is not heard, remove drawer assembly (see Section IX) and ground it solidly to burner metal. Repeat test c. above.
  4. TURN MANUAL GAS COCK KNOB ON. Connect manometer to the manifold gas pressure tap and, during trial for ignition, check the gas pressure:
    - a. Pressure should be between 1.5" and 3.5" W.C. NATURAL (10.0 W.C." PROPANE), and steady. Verify per Section VII that the spud orifice size and manifold pressure are correct.
    - b. Zero, erratic, low or high pressure: confirm that the inlet pressure to the combination valve is between 5.0" and 14.0" W.C. for NATURAL (11.0" to 14.0" W.C. PROPANE), during standby and during trial for ignition.
    - c. If manifold pressure is zero, below 1.5" or above 3.5" W.C. NATURAL (10.0" W.C. PROPANE) or erratic, replace combination valve.
- III. FLAME ON ONLY DURING 6-SECOND TRIAL FOR IGNITION.
- A. With motor running check burner line voltage terminals for 120V as follows:
    1. Between strip terminals 1 and 2 - 120V; voltage OK.
    2. Between strip terminals 1 and GND - 120V; ground OK.
    3. Between strip terminals 2 and GND - 0"V; no backfeed OK.
  - B. Follow reset procedure as specified in step II.B.
    1. Check flame rod position per Figure 7.
    2. Check sensor wire for continuity.
    3. Connect DC microammeter in series Electronic Control SENSE terminal and sensor wire. With flame on, flame signal should be at least 2 microamps.
  - C. IMPORTANT: If changes are made in the Main Spud Orifice size, Manifold Gas Pressure or Primary Air Adjustment, change the installation data tag accordingly.
- IV. SHORT FLAME.
- A. Low gas pressure.
  - B. Primary air adjustment open too far.
  - C. Main spud orifice too small.
- V. LONG HAZY FLAME.
- A. High gas pressure.
  - B. Primary air adjustment closed too far.
  - C. Dirty blower wheel.
  - D. Main spud orifice too large.
- VI. GAS FAILS TO SHUT OFF.
- A. Defective combination valve.
- \* Normal low voltage:  
Motor running - 24V minimum.  
Combination valve energized - 21V minimum.

