

# Installation and Service Instructions

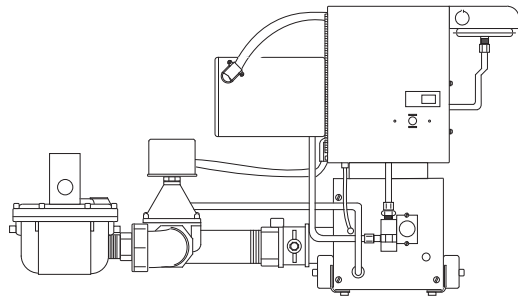

★ MADE in the USA ★

## Unipower G56B G57B G58B G69B Gas Power Burners



- In the United States, installation must conform with local codes or in the absence of local codes, with the National Fuel Gas Code, ANSI Z223.1-latest edition available from American National Standard Institute. Further reference should be made to the recommendation of your fuel supplier.
- In Canada, installation must conform with local codes or in the absence of local codes, with Installation Codes for Gas Burning Appliances and Equipment, CGA Standard CAN/CGA 1-B-149.1 or 2.
- **⚠ WARNING: Additions, changes, conversions and service must be performed by an authorized Midco representative, service agency or the fuel supplier. Use only MIDCO specified and approved parts.**

- **INSTALLER:** Inform and demonstrate to the user the correct operation and maintenance of the gas utilization equipment. Inform the user of the hazards of storing flammable liquids and vapors in the vicinity of this gas utilization equipment and remove such hazards. Affix this manual and associated literature to the burner.

**CODE COMPLIANCE IS THE SOLE RESPONSIBILITY OF THE INSTALLER.**

- **USER:** Retain this manual for future reference. If other than routine service or maintenance as described in this manual and associated literature is required, contact a qualified service agency. **DO NOT ATTEMPT REPAIRS.** An inadvertent service error could result in a dangerous condition.

**AVOID ERROR IN PARTS SELECTION.** When ordering use complete MIDCO Part Number and Description. Furnish Burner Model Number, Bill of Material Number and Serial Number (if available) from the specification plate found on the product.

**IMPORTANT:** Availability of parts as well as specifications are subject to change without notice. Please consult factory for item availability.

**⚠ WARNING: If the information in these instructions is not followed exactly, a fire or explosion may result, causing property damage, personal injury or death.**

Do not store or use gasoline or other flammable vapors and liquids in the vicinity of this or any other appliance.

**WHAT TO DO IF YOU SMELL GAS:**

- Do not try to light any appliance.
- Do not touch any electrical switch; do not use any phone in your building.
- Immediately phone your gas supplier from another building. Follow the gas supplier's instructions. If you cannot reach your gas supplier call the fire department.

Installation and service must be performed by a qualified installer, service agency or the gas supplier.

**BURNER MODEL:** \_\_\_\_\_

**BILL OF MATERIAL NUMBER:** \_\_\_\_\_

**SERIAL NUMBER #:** \_\_\_\_\_

**WIRING DIAGRAM:** \_\_\_\_\_

**FOR SERVICE CONTACT**

**Name:** \_\_\_\_\_

**Address:** \_\_\_\_\_

**Phone:** \_\_\_\_\_

**Date of Installation:** \_\_\_\_\_



**Midco**  
INTERNATIONAL

Midco® International Inc.  
4140 West Victoria Street  
Chicago, Illinois 60646  
toll free 866.705.0514  
tel 773.604.8700  
fax 773.604.4070  
web www.midcointernational.com  
e-mail sales@midcointernational.com

**SAFETY INFORMATION TERMS:** The following terms are used to identify hazards, safety precaution of special notations and have standard meanings throughout this manual. They are printed in all capital letters using a bold type face as shown below, and preceded by the exclamation mark symbol. When you see the safety alert symbol and one of the safety information terms as shown below, be aware of the hazard potential.



- DANGER:** Identifies the most serious hazards which will result in severe personal injury or death.
- WARNING:** Signifies a hazard that could result in personal injury or death.
- CAUTION:** Identifies unsafe practices which would result in minor personal injury or product and property damage.



*Quality Designed for Proven Performance*



414  
**8470 86**  
Printed in USA

# Specifications and Installation Instructions

## Specifications

### SPECIFICATIONS

BURNER STYLE..... Power Type  
 PILOT TYPE..... Intermittent, Spark Ignition  
 PILOT SAFETY..... Instantaneous Electronic Flame Safeguard  
 STANDARD VOLTAGE  
 CONTROLS (FIELD WIRING) 120/1/60  
 MOTOR..... 115/1/60 (except G69B-115/230/1/60)  
 U.L. LISTED

Model		Max Input <sup>1</sup> MBTU/Hr. *	Max Air SCFM <sup>5</sup>	Inlet Gas Pressure Required <sup>2</sup>		Burner Manifold Pressure <sup>1,4,5</sup>		Min Input <sup>3</sup> MBTU/Hr.	Motor HP (3450 RPM)	Recommended Combustion Chamber Sz
Natural Gas (1,000 BTU/ cu. ft.)	Propane Gas (2,500 BTU/ cu. ft.)			Natural	Propane	Natural	Propane			
G56B	G56BP	1075	224	5.0" W.C.	5.0" W.C.	2.2" W.C.	1.2" W.C.	300	1/6	42" x 18"
G57B	G57BP	1500	313	7.0" W.C.	5.0" W.C.	4.1" W.C.	2.6" W.C.	300	1/3	48" x 21"
G58B	G58BP	1800	385	6.7" W.C.	6.0" W.C.	4.6" W.C.	3.8" W.C.	500	1/2	50" x 24"
G69B	G69BP	2500	521	7.5" W.C.	8.0" W.C.	4.2" W.C.	3.3" W.C.	800	3/4	60" x 27"

**Table 1 - Burner Specifications**

- <sup>1</sup> Values given based on +0.000" W.C. firebox pressure, altitudes to 2000 feet. Derate burner for altitudes over 2000 feet by 4% for each 1000 feet over sea level.
- <sup>2</sup> Maximum inlet pressure both gases: 14" W.C. Refer to Section VI Piping for high pressure.
- <sup>3</sup> Modulating and two-step burners are limited to a 3 to 1 turndown ratio.
- <sup>4</sup> Manifold pressures are approximate and will vary slightly according to job condition. See Section VII para. 11.
- <sup>5</sup> Pressures are based on 25% excess combustion air.
- <sup>6</sup> SCFM = Standard Cubic Feet/Minute.

Model	Min. Firing Rate MBH *	Maximum Capacity in MBH at Comb. Ch. - Back Pressure			Max Back Pressure in " W.C.	Maximum MBH * at Max. B.P.
		0" W.C.	.25" W.C.	.5" W.C.		
G56B	300	1075	950	875	0.7	700
G57B	300	1500	1400	1325	0.8	1325
G58B	500	1850	1750	1650	1.0	1400
G69B	800	2500	2375	2275	1.0	2100

\* 1 MBH = 1,000 BTU/Hr

**Table 2 - Maximum Capacity at Specified Back Pressures**

## Part 1 Installation

### I Ventilation

**⚠ CAUTION: Unipower GB -Series are not intended for outdoor installation and must be protected from excessive moisture. Provide adequate clearance for service and proper operation.**

Open basements will generally allow sufficient air infiltration, so special provisions will seldom be required. If the heating plant is located in a separate furnace room or in an unusually tight basement, permanent means must be provided to supply an ample volume of fresh air for combustion and boiler room ventilation. A direct opening to the outside air should be provided sized on the basis of 1/2 square foot of free opening for each 1,000,000 BTU of burner rating when the vent connector is equipped with a barometric draft control, 1 1/2 square feet when equipped with a draft hood. If the ventilation opening is screened, it should be of 1-1/4" mesh. The opening should be located at least six feet over ground level to prevent accidental obstruction. If a direct opening to the outside air is not available, an ample sized air duct can be run to the nearest outside air source; or, if practical, open stairwells or building corridors connecting to an outside wall having a ventilating opening can be used for this purpose, provided that no possibility of accidental closure exists.

While the spark ignition pilot system performs successfully under moderate or momentary back draft conditions, it is not intended for operation under sustained reverse draft, for example in a building with large ventilating fans but with insufficient make-up air. Even if burner operation is successful this condition must be corrected to prevent the hazard of drawing flue gases into the building.

Consult your local gas company when doubt exists concerning boiler room ventilation.

The heating system, both the gas utilization equipment and the distribution system, should be in good repair and sufficient to properly heat the building. It should be determined if any serious faults are present that would cause excessive fuel consumption, unsafe operation or improper heating, and measures taken to correct them. After the grates and grate operating parts have been removed from the firebox, the boiler interior should be thoroughly cleaned, removing all adhering dirt, tars, scale and soot. All joints should be cemented to prevent excess air infiltration into the boiler. Clean out doors should be checked for close fit, and sealed with furnace cement if they fit poorly.

Firing door catches should be filed off or otherwise arranged so that the door will open easily to relieve pressure. No positive catches should be used. The use of a spring type door holder is recommended.

The UNIPOWER gas burner is designed for "in-shot" firing. It can be fired into the ash pit of a boiler designed for solid fuels, or it can be fired into the primary heat exchanger of a boiler designed for liquid or gaseous fuels. The ash pit installation requires a refractory lining. The combustion chamber serves to contain and promote combustion and to protect non-heat exchange surfaces from direct flame contact. Built-up combustion chambers should be made of 2600° insulating firebrick. As an alternative, a monolithic floor can be cast in place, using a high temperature (2400°), light weight insulating refractory. Check with your supplier to determine the thickness which will yield equivalent insulating qualities. The top of the combustion chamber should be positioned 2 to 6" above the base of the heat exchanger. If the combustion chamber is to be set directly on the floor, provide a minimum of 1/2" insulating millboard or magnesia block underlay for floor protection. Use high temperature fill such as vermiculite in voids around the combustion chamber. Any portion of the heat exchanger not exposed to circulating air or water should be covered with insulating firebrick.

The combustion chamber sizes given in Table 1 are based on the maximum rated burner capacity. If the input is to be permanently set at a reduced rate the combustion chamber floor area can be reduced proportionately to the proposed input, with the length as closely proportioned to twice the width as possible.

Where recommended size combustion chambers (225,000 BTU/sq. ft.) can be accommodated, the type of construction shown in Figure 1 should be used. If lack of space prohibits use of this construction, higher BTU values per square foot can be allowed for by using the constructions shown in Figure 2 and 3.

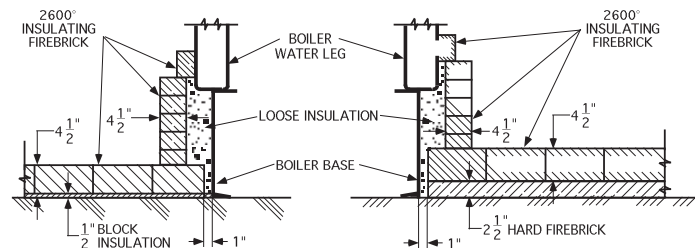

**Figure 1 - Typical Floor And Wall Construction For 225,000 BTU Per Square Foot. (Standard)**

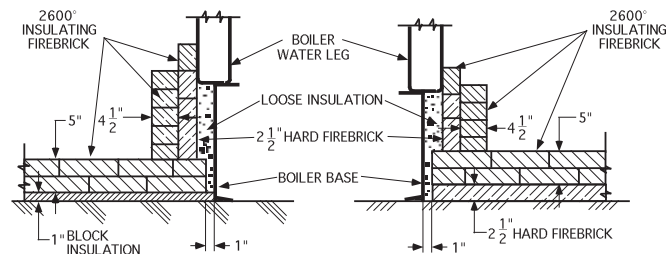

**Figure 2 - Typical Floor And Wall Construction For 275,000 BTU Per Square Foot.**

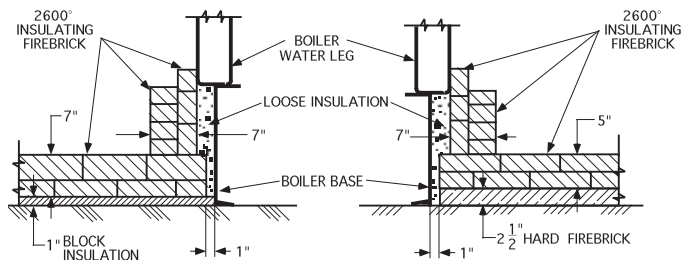

**Figure 3 - Typical Floor And Wall Construction For 350,000 BTU Per Square Foot. (Maximum)**

# Installation

## III Combustion Chamber Continued

The back wall of the combustion chamber should be carried 2 or 3 courses higher and overhung to deflect the flames from direct impingement on the rear heat exchanger surface. Hard firebrick should be used to prevent erosion of the brick by high velocity gases.

The burner is equipped with a mounting flange for direct attachment to the boiler front, and mounting brackets for legs. Use both if necessary for rigid installation. The burner nozzle must not extend into the combustion chamber. It should be sealed into the opening as shown in Figure 4.

**⚠ WARNING: BURNER CABINET MUST BE MOUNTED IN ORIENTATION IN FIGURES 4 AND 7. ANY OTHER MOUNTINGS MAY CAUSE A DANGEROUS CONDITION, AND WILL VOID BURNER WARRANTY AND AGENCY APPROVALS. NON-STANDARD ARRANGEMENTS MAY BE AVAILABLE FOR SOME MODELS-CONSULT FACTORY FOR DETAILS IF REQUIRED.**

The refractory lined combustion chamber can be omitted in "Scotch Marine" and "Steam Generator" boilers or warm air furnaces that include no ash pits. The burner is fired directly into the heat exchanger, requiring no refractory unless the combustion chamber is so short that flame would impinge excessively on the rear heat exchanger wall (this particularly important in a warm air furnace). Refractory protection is recommended if the length of the primary chamber is less than 20% larger than the length given in Table 1. In any case, the burner entry wall must be refractory lined if it is not a heat exchanger surface.

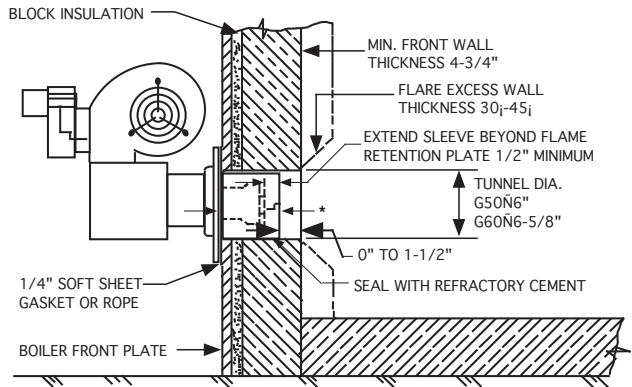

\* ADJUSTABLE NOZZLE SLEEVE LENGTH-5" TOTAL ADJUSTABLE NOZZLE INSERTION DEPTH VARIABLE FROM 5" TO 10" TO ALLOW FOR THICKER COMBUSTION CHAMBER WALL.

Figure 4 - Construction at Burner Entrance

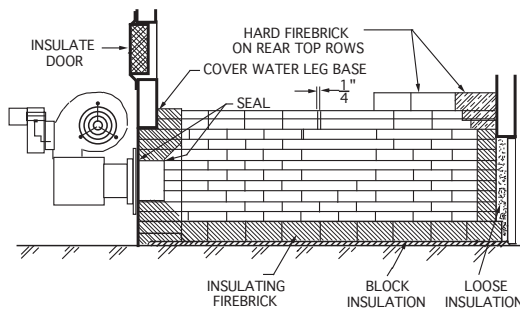

Figure 5 - Conventional Boiler - Small Firebox

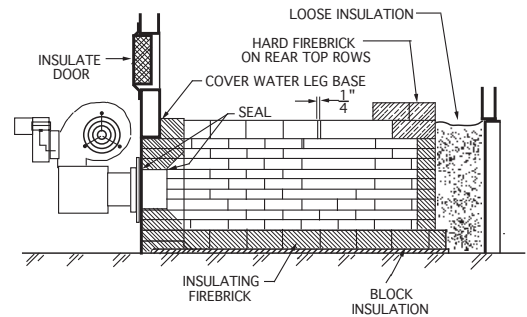

Figure 6 - Conventional Boiler - Large Firebox

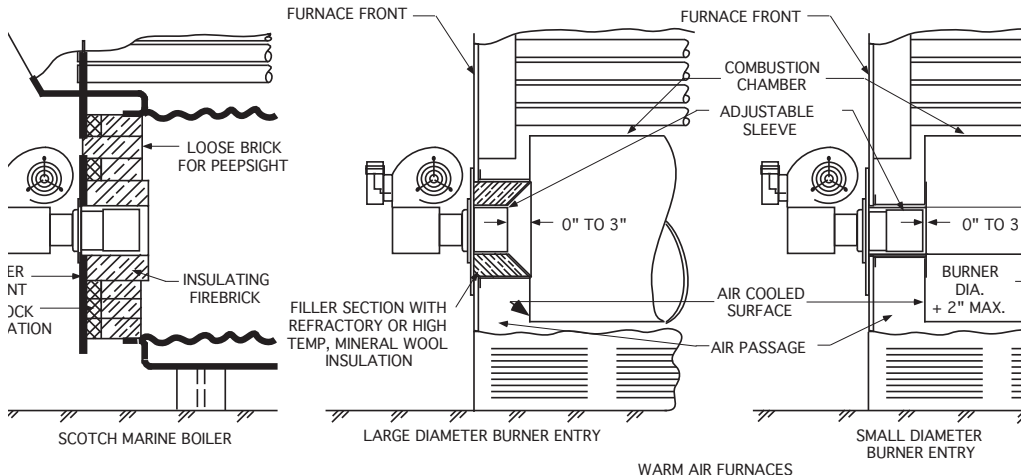

Figure 7 - Tubular Combustion Chambers

### Firing Door Installations

It is advantageous, on occasion, to fire through the boiler firing door. For example, pitting can be avoided on low base boilers, damage to the burner can be avoided if basement flooding is prevalent, or the combustion chamber volume can be reduced in boilers with unusually large ash pits.

Great care in planning will be required for firing door applications since flame impingement on boiler surfaces is more probable. Do not fire a boiler which contains a drop section directly in the path of the flame, or do not fire over a water grate in a smokeless type boiler. The firebox length must be great enough to exceed the combustion chamber lengths given in Table 1 by at least 20%.

When raising the floor, maintain sufficient firebox volume to limit the heat release to 50,000 BTU per hour per cubic foot or less. Use the entire floor as a combustion chamber and cover the water leg base to 6" from the bottom. Floor construction should conform to Figures 1 to 3.

Firing door installations will usually entail removal of the grates. Figure 8 shows a typical installation. A steel plate floor can be supported from the grate lugs, if suitable. In any case, the floor must be rigid enough to prevent sagging, being supported by brick piers as necessary. If firing over the grate, level it off with rubble of common brick or firebrick if necessary; then cover over with insulating block before laying the refractory floor.

The hearth of worm feed stokers can be used as a floor base. Level off the hearth to a suitable height, remove the worm feed mechanism and fill the tuyere with rubble. Cover at least the tuyere area with block insulation; if using castable refractory, pour a new floor over a leveling surface of sand. The external stoker parts should be removed to eliminate clutter under the burner.

The burner mounting in the door must be rigid and refractory lined as shown in Figure 8. The burner nozzle must not protrude directly into the combustion chamber. The refractory liner must extend beyond or be flush with the burner face as shown in Figure 4. A sheet metal rim should encase the refractory up to the inside of the boiler wall. It should be intermittently bent inward to retain the refractory, or other means of anchoring should be provided.

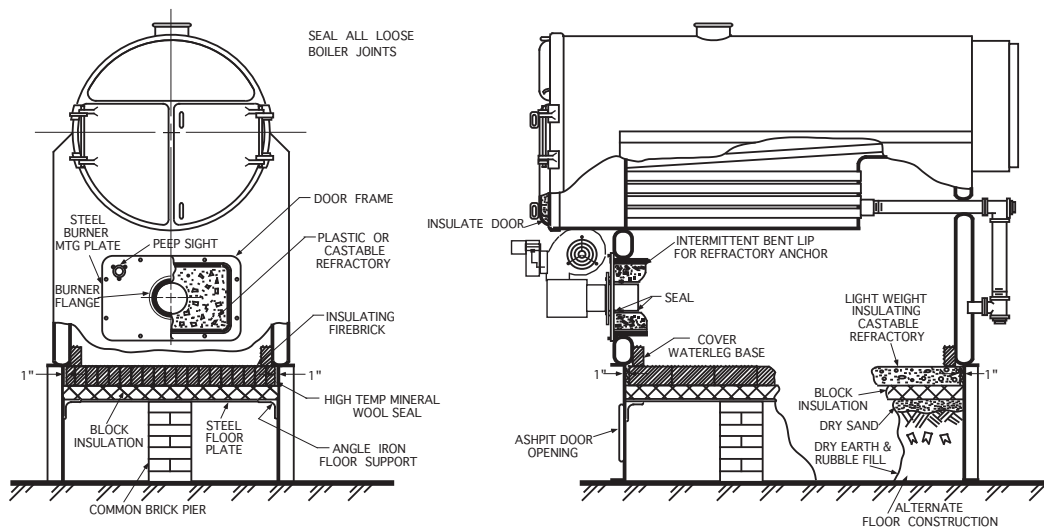

**Figure 8 - Firing Door Installation in Three Pass Boiler**

As an alternate, the burner mounting plate can be extended externally to locate the nozzle face and refractory wholly within the door opening. Seal carefully to prevent flue products from entering the boiler room. In double door boilers it is recommended that the openings be enlarged to a single opening by removing the center post so that the burner can fire in the center. If a pressure part of the boiler must be cut away, be sure to make modifications in accordance with your local code covering boiler repairs.

Since firing door installations will generally leave no openings for flame observation, a peep sight must be installed in the burner mounting plate.

# Installation

## IV Chimney, Vent Connector and Draft Control

**⚠ WARNING:** The chimney shall be inspected for unsafe conditions such as deteriorated masonry and excessive soot or other blockage or potential blockage. Installation must conform with local codes or in the absence of local codes with NFPA, ANSI Z223.1-latest edition.

**⚠ WARNING:** No movable vent connector damper is permitted on any gas conversion installation. The chimney should be inspected for unsafe conditions such as deteriorated masonry and excessive soot or other blockage or potential blockage. Check your local authorities for regulations covering barometric draft regulators on gas equipment.

**⚠ WARNING:** The vent connector shall not be connected to a chimney already venting solid fuel burning equipment, an incinerator or an open fire place.

The UNIPOWER burner does not depend on chimney draft. Combustion air is supplied by the forced air blower, which is sufficient to supply adequate air for any normal boiler. This reduces the function of the chimney to removal of flue products from the boiler. A chimney height of 15' above the boiler flue outlet will generally prove ample if the recommended, or larger, vent connector and chimney diameters are used. The chimney must of course extend several feet over the roof of the building, or adjacent buildings. Vent connector material should be 24 gauge or heavier steel, galvanized to resist corrosion. The horizontal run of vent connector should be pitched upward from the appliance flue outlet at least 1/4" to the foot. Avoid excess elbows or other constructional features that would create excessive resistance to flow of flue products. Fasten joints with sheet metal screws to prevent sagging. The vent connector should be maintained at least 6" from combustible building materials; more if it is uninsulated. Where it passes through partitions constructed of combustible materials a ventilated thimble should be used. Refer to your local building codes. The vent connector should be firmly cemented into the chimney but must not extend beyond the inner face. Where two or more appliances use the same chimney, be sure not to enter the chimney with both flue pipes at the same level.

Do not arbitrarily reduce the vent connector size, since a boiler back pressure can build up, leading to possible leakage of flue products into the boiler room.

Chimney construction can be either of brick, preferably tile lined, or of steel. Joints in the chimney should be smooth and leak free to prevent uncontrollable air infiltration. They should be made so that condensation, if any, will not collect in the joints or leak to the outside.

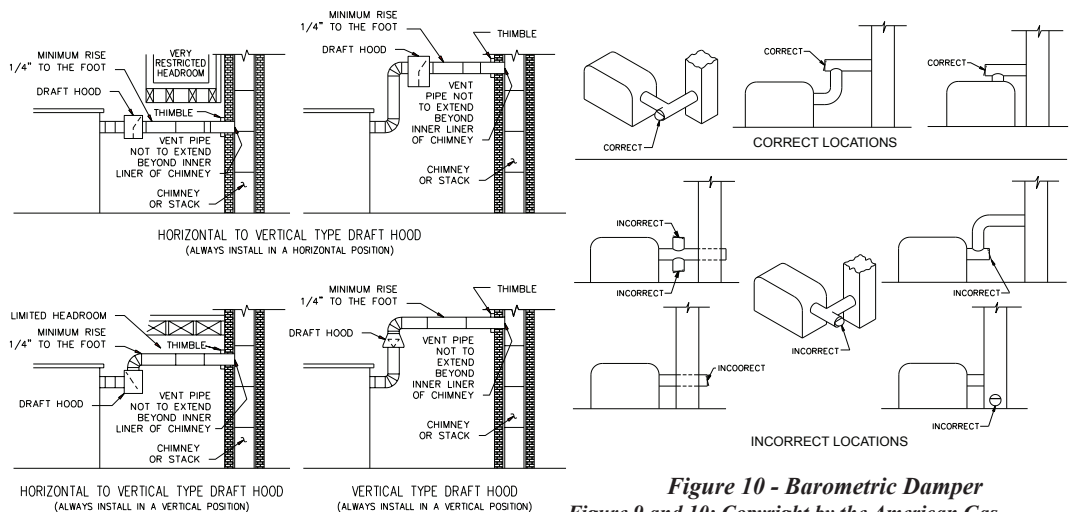

Figure 9 - Draft Hoods

Figure 10 - Barometric Damper  
Figure 9 and 10: Copyright by the American Gas Association. Used by permission of the copyright holder.

If the vent connector must be extra long, the area of the pipe and chimney should be increased, or the chimney height must be increased, or both. Never allow the horizontal length of the vent connector to exceed the height of the chimney.

Two kinds of draft control are acceptable; an A.G.A. type draft hood as illustrated in Figure 9, or a barometric damper as shown in Figure 10. Use of a draft hood is usually limited to burners with lower range capacities, while a barometric draft control is suitable for all capacities. Application should depend on the requirements of the installation.

If a draft hood is used, it should be of the same size as the vent connector and should be located higher than the highest part of the heating appliance flue passage.

If a barometric damper is used, it should be of the double-swing type, which opens freely outward to afford downdraft protection irrespective of settings made to the balancing weights for updraft control. The damper should be located so it is free to swing without interference from surrounding objects so that the velocity pressure of the flue gases does not interfere with its operation. See Figure 10 for proper installation.

When any vent connector passes through a partition the draft control must be located in the same room as the heating appliance. A device which will automatically shut off gas to the burner in the event of sustained backdraft is recommended if such backdraft might adversely affect burner operation or if flue gas spillage might introduce a hazard. If such a device is used, it shall be of the listed type and installed and adjusted by a qualified service technician in accordance with the manufacturer's instructions.

The burner, when installed, must be wired and grounded in accordance with local codes, or, in the absence of local codes, with the National Electric Code ANSI/NFPA No. 70-latest edition. In Canada, refer to CSA Standard C22.1, "Canadian Electrical Code Part 1."

*V Electrical*

**⚠ CAUTION: REFER TO THE SEPARATE WIRING DIAGRAM INCLUDED WITH EACH BURNER.**

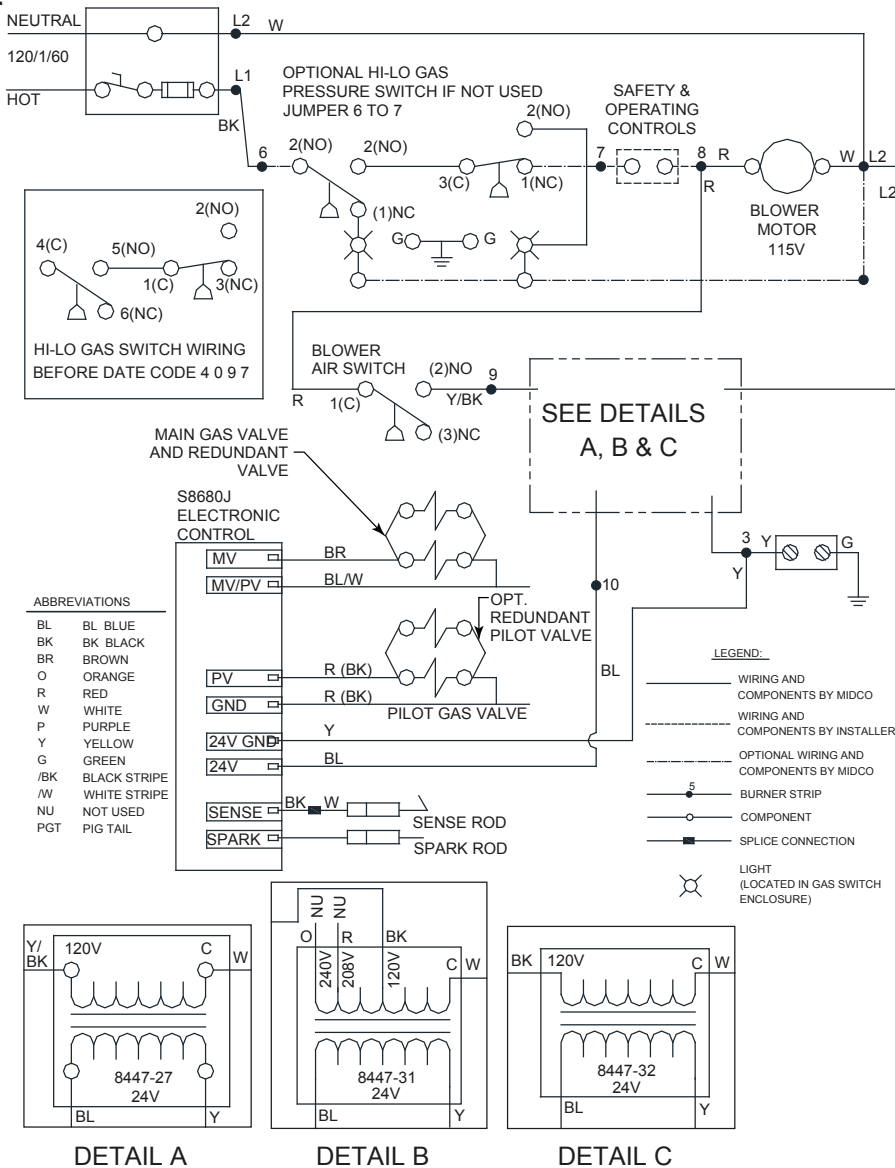

**Figure 11 - Wiring**

# Installation

## V Electrical Continued

When wiring, be sure that the electric power take-off is connected to a permanently live circuit and use multiple 14 gage copper wire conductors. Provide a fused disconnect switch in the burner circuit. Each installation must include a limit control to guard against excess temperature or steam pressure. Steam or vapor systems will require a low water cut-off.

## VI Piping

For the usual low pressure gas supply system, 5" to 14" W.C. NATURAL (11" to 14" W.C. Propane) use Table 3 to find the recommended gas supply line size.

Piping follows normal practices and should be connected to the burner in the manner shown in Figure 12. If the piping must be rearranged because of space limitations be sure to carry out the sequence of components illustrated. While the pilot regulator can be mounted in any position, the main regulator should be mounted upright and in a horizontal run of pipe.

Run full size pipe or tubing from regulator vent openings to outside of building. Provide no traps in the vent lines and terminate away from all doors and windows; also make provisions for keeping rain and foreign objects from entering the vent piping.

When high supply gas pressure is encountered, as in the case in many industrial plants, the gas line size can be reduced to allow for a greater pressure drop; however, the size must be sufficient to delivery burner rating pressure.

**⚠ CAUTION: High gas pressure supply lines require the proper pressure reducing regulators. Install two separate high pressure regulators, of the Tight Shut-Off type upstream of the low pressure regulators. One sized for main gas input, and one suitable for the minimum flow regulating capacity of the pilot.**

The high pressure regulators may be substituted for the low pressure regulators. If high pressure regulators are used as substitutes, they must be adjustable down to a minimum of 2" W.C. outlet pressure for the pilot and 5" W.C. for the main gas. They must be adjustable down to the maximum burner inlet pressure rating (14" W.C.).

**⚠ DANGER: Explosion hazard.  
Do not use oxygen for pressure testing. An explosion could occur during initial start-up.**

When the gas supply line is about to be put into service it must be tested to insure that it is gas tight. Use air or inert gas under pressure and test with soap and water or other liquids to locate leaks.

**⚠ CAUTION: Because it is difficult to accurately control pressure, disconnect all low pressure (14"W.C. max.) components (main and pilot) during supply pipe leak testing. Exposing low pressure regulators and valves to a pressure over 1U2 PSIG (14"W.C.) will damage components and void their warranties.**

Gas Supply Pipe Size N.P.T.	Type of Gas	Approximate Capacity - MBH				
		Length of Pipe - Feet				
		20	40	60	100	200
1"	Natural	350				
	Propane	550	385	300		
1 - 1/4"	Natural	730	500	400	300	
	Propane	1150	785	630	480	330
1 - 1/2"	Natural	1100	760	610	460	320
	Propane	1730	1200	960	725	500
2"	Natural	2100	1450	1150	870	610
	Propane	2500	2280	1800	1370	960
2 - 1/2"	Natural	2500	2300	1850	1400	980
	Propane		2500	2500	2200	1550
3"	Natural		2500	2500	2500	1700
	Propane				2500	2500

**⚠ CAUTION: Do not exceed maximum rated capacity of burner model - See Tables 1 and 2**

Capacities shown are for total pressure drop of .3" W.C. For higher permissible pressure drops consult your fuel supplier.

Source: Gas Engineers Handbook - 1974

*Table 3 Schedule 40 Pipe Capacity Chart*



Before gas is introduced to the system, a check must be made to see that there are no open fittings and to make sure the burner main and pilot manual valves are closed. After checking above, purge the gas line up to the burner inlet. Purging the air from the gas supply line at this step will expedite the first light-off.

**⚠ CAUTION: Purge outside the building. Do not purge into the gas utilization equipment combustion chamber.**

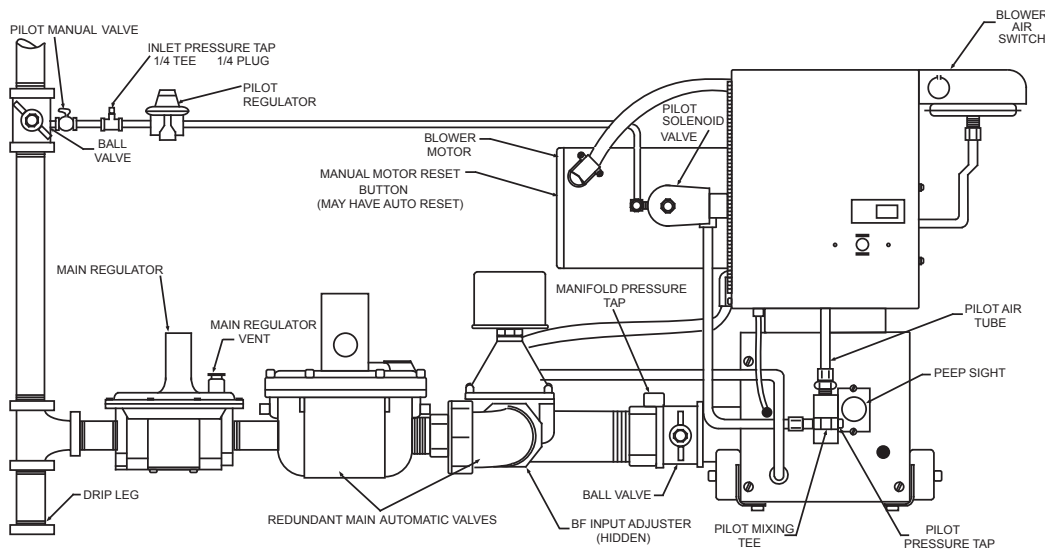

*Figure 12 - Piping Connections*

**⚠ WARNING: Repeated unsuccessful attempts to light may result in accumulated gases in gas utilization equipment and chimney. To prevent these gases from reaching an explosive level, periodically purge the gas utilization equipment.**

**⚠ CAUTION: All cover plates, guards, and enclosures must be maintained in place at all times except during maintenance and servicing.**

**⚠ CAUTION: Optional equipment and/or special limit controls such as high/low gas pressure switches can alter the start-up procedure. See Section XIV SPECIAL EQUIPMENT.**

### Special Equipment

1. Check the piping for leaks. A quick way to do this is to close the main manual shut-off valve and manual pilot valve, then turn on the gas pressure to the gas supply line and observe the meter test dial. There should be no movement of the test dial hand for at least twenty minutes. All other gas appliances must be completely shut off during this test (including pilots). If a leak is detected it should be located with a soap suds test. Test the main automatic valve for tightness. (see Section XII for instructions). The ball valve is intended to be open at all times except when testing for main valve leakage. The Main Manual Shut-Off Valve must be used for manual gas shut-off.
2. Make sure that the burner main and pilot gas lines are completely purged of air. Do not purge into the combustion chamber. Purge outside the building.
3. Make sure the burner power switch is off, manual valve is closed, pilot manual valve is closed, motor is free to rotate, and flame safeguard reset button is set.
4. Make the proper settings on all limit controls and set controller to call for heat.
5. Set blower air shutter wide open.

### VII Initial Start-UP

# Installation

## VII Initial Start-UP Continued

6. Turn on the line switch, and allow motor to run through the pre-purge and ignition cycle. Check the blower wheel for proper rotation. Viewing from the motor shaft end (Blower Inlet side), rotation should be counter clockwise. After a short run, the flame safeguard will lock out, stopping the motor. Wait one minute, then reset the flame safeguard.

7. Turn on pilot manual valve. With Main Manual Shut-Off Valve still closed, turn on main line switch. Motor will start. When pre-purge period has elapsed, flame safeguard will energize pilot solenoid valve and spark generator. When flamerod senses pilot flame, the flame safeguard will energize the main valves. No main flame will occur due to closed Main Manual Shut-Off Valve. Quickly observe pilot flame. If no flame, or if weak, screw in pilot regulator adjustment. If the flame is rich and floating from the pilot tip, back off the pilot regulator. Set to achieve the largest stable blue flame with a base that burns firmly within the pilot tip. The best operating pressure is usually 3-1/2" to 4" W.C.. Test for ignition and stability several times, cycling the burner with both open and closed air shutter. Ignition and relay response will be prompt with a good flame. Check flame signal with a AC micrometer. Pilot should be set to yield the highest steady reading, at least 2 microamps AC and as high as 5 microamps.

8. Check operation of the electronic flame detection circuit by turning off the pilot manual valve with pilot burning and main manual shut-off valve still closed. The circuit to the main automatic valve should be broken when the pilot goes out.

\*9. Turn off line switch to stop the burner. Reset flame safeguard. Set blower air shutter about 1/4 open. Loosen gland nut on Butterfly Valve and temporarily lock air shutter wide open (slot in shaft parallel to flow).

10. Turn on main line switch. After the main valve is energized, slowly open main manual shut-off valve until the main flame ignites. Then, opening the air shutter as required to maintain a suitable flame, slowly open the main manual shut-off valve to the wide open position or until, with the air shutter wide open, the main flame becomes excessively rich.

\*11. The manifold pressures shown in tables 1 and 5 may be used to determine the approximate gas input settings. The gas input for Natural gas models can be determined by timing the gas meter. Accurately time test dial for the number of seconds for one revolution and use the following formula. All other gas utilization equipment must be off.

$$\frac{3600 \times \text{test dial size} \times \text{BTU value}}{\text{no. of seconds for one rev. test dial}} = \text{BTU / Hr.}$$

Then divide by 1,000 for MBH value.

$$\text{Example} \quad \frac{3600 \times 1 \times 1000}{5} = 720,000 \text{ BTU / Hr.} = 720 \text{ MBH}$$

For Propane gas, consult your supplier for method of determining firing rate.

**⚠ CAUTION: The manifold pressures shown in tables are both the blower air pressure and the gas pressure. Air shutter adjustments will effect manifold pressure and input.**

Clock the meter gas rate and (if necessary) reset the main regulator to control gas flow at about 10% over burner rating or over desired input with Main Manual Shut-Off Valve wide open. Turning the adjustment screw clockwise on main regulator increases pressure and flow rate, reverse decreases. Do not adjust the regulator past the point where no further change in gas flow is noted. "Close" off Butterfly Valve to the desired maximum input rate, secure gland nut, and replace cap. Reset the blower air shutter to provide fairly long flame, blue at the burner face, orange or red at the tips. Flashes of yellow may be visible. Close firing door for a few seconds; then open and quickly observe fire. If a purple haze is noted at the rear of the firebox, lack of air is indicated and air shutter should be opened wider.

Refer to Table 4 if the manifold pressure is to be used as a guide to gas input.

12. Check the flue gas temperature at the boiler flue outlet. It should be above 325° but not exceeding 550°. Excessive flue temperatures result in low efficiencies. Low flue gas temperatures may cause excessive condensation. Reset input if necessary to adjust stack temperature; or if temperature is too low, portions of the heat exchanger surface can be blocked off with insulating firebrick.

13. Make the final setting of the air shutter by checking the flue gases with an "Orsat" or similar combustion testing instrument. There should be no carbon monoxide and the carbon dioxide content should be approximately 9.5% for NATURAL and 12.1% for PROPANE, or within the limits prescribed by the local fuel supplier.

14. Check the draft control to make sure there is no spillage of flue products into the boiler room. This test should be performed under the most severe possible ventilating conditions. For example, perform this test with all doors and windows tightly shut and any ventilating fans in the building operating.

15. Start and stop the burner several times with the controller and the limit controls to check their operation.

16. Reset controller and limits controls to their desired settings.

\*Refer to Trouble Chart

Model	Capacity MBH *	Manifold Pressure (" W.C.)		
		Air Only	Gas On Natural Propane	
G56B	1075	1.00	2.10	1.45
	1000	0.87	1.82	1.25
	900	0.70	1.47	1.01
	800	0.55	1.16	0.80
	700	0.42	0.89	0.61
	600	0.31	0.65	0.45
	500	0.22	0.45	0.31
G57B	300	0.08	0.16	0.11
	1500	1.90	4.10	2.79
	1300	1.43	3.08	2.10
	1200	1.22	2.62	1.79
	1000	0.84	1.82	1.24
	900	0.68	1.48	1.01
	700	0.41	0.89	0.61
G58B	600	0.30	0.66	0.45
	300	0.08	0.16	0.11
	1850	2.65	4.60	3.75
	1700	2.24	3.88	3.17
	1600	1.98	3.44	2.80
	1500	1.74	3.02	2.47
	1200	1.11	1.94	1.58
G69B	1000	0.77	1.34	1.10
	800	0.50	0.86	0.70
	500	0.19	0.34	0.27
	2500	2.25	4.15	3.65
	2200	1.74	3.21	2.83
	2000	1.44	2.66	2.34
	1800	1.17	2.15	1.89
G69B	1500	0.81	1.49	1.31
	1200	0.52	0.96	0.84
	1000	0.36	0.66	0.58
	800	0.23	0.42	0.37
	800	0.23	0.42	0.37

This table is provided as a guide to use the **INPUT ADJUSTING METHOD** to approximate final settings. The valve train **MUST** be tested for tightness and the pilot adjusted for proper operation before proceeding. Refer to Section VIII of the Installation and Service Instructions.

1. Install a Manometer (not a pressure gauge) in the manifold pressure tap.
2. Close the Main Manual Gas Valve.
3. Close the Input Adjuster (butterfly valve).
4. Turn the burner on.
5. Adjust the air shutter to the "Air Only" pressure shown for the desired MBH.
6. Open the Main Manual Gas Valve.
7. Slowly open the Input Adjuster until the observed manifold pressure equals the Gas On pressure for the desired MBH.
8. Take combustion readings and confirm the input rate by clocking the gas meter.
9. Adjust the air shutter and/or the Input Adjuster as needed.
10. Repeat steps 8 and 9 until you have the desired input rate with clean combustion \*\*.
11. Refer to section VIII of the Installation and Service instructions for final Main Gas Regulator adjustment procedures.

For capacities not shown:  
 $P_2 = P_1 \times (MBH_2 / MBH_1)^2$

\* 1 MBH=1000 BTU/Hr  
 \*\* Approximately 25% excess air (4.5% O<sub>2</sub>)

**ALL FIGURES ARE APPROXIMATE. Actual figures will vary depending upon application and ambient conditions.** Based on 0 pressure over the fire at **Standard Air and Specific Gravities** of .64 for NATURAL GAS, and 1.52 for PROPANE GAS. It is the responsibility of the installer to make final adjustments to insure proper and safe operating conditions, and to comply with all codes and guidelines that may apply at the installation site. Contact the local Utility for any requirements and recommendations they may have. In the absence of any local codes, guidelines or requirements, refer to the latest edition of the **National Fuel Gas Code, ANSI Z223.1-1992.**

Table 4: Approximate "G" Series Capacities At Specified Manifold Pressures.

# Installation and Service

## *VII Initial Start-UP Continued*

After the initial start-up procedure the following steps can be followed for routine start-up and shut-down on a seasonal or extended basis.

### **BURNER START-UP**

1. Make sure line switch is off.
2. Set controller to call for heat.
3. Open firing door
4. Open Main and Pilot Manual Valves.
5. Reset flame safeguard.
6. Turn on line switch.
7. Close firing door after main flame ignites.
8. Reset controller to desired setting.

### **BURNER SHUT DOWN**

1. Turn off main line switch.
  2. Close Main Manual Valve
  3. Close pilot manual Valve
- 

## *Part 2 - Service*

**⚠ CAUTION: BE SURE THAT THE MAIN MANUAL SHUT-OFF, MANUAL PILOT VALVE, AND POWER DISCONNECT BURNER SWITCH ARE TURNED OFF BEFORE REMOVING ANY PARTS FOR SERVICE.**

**⚠ CAUTION: COVER PLATES, GUARDS, AND ENCLOSURES MUST BE IN PLACE AT ALL TIMES EXCEPT DURING MAINTENANCE AND SERVICE.**

---

## *VIII Burner Box and Firing Head*

The UNIPOWER burner head is of the nozzle mixing (non-premix), flame retention type. This design accommodates a high capacity without flame lift off and a low capacity without flash back.

The burner box serves as an air plenum chamber and a frame to which all other parts are assembled. Blower air enters the box and passes around the outside of the gas manifold and through the retention plate. Gas passes through ports in the manifold, then through the retention plate where it is mixed with the blower air by turbulence caused by the retention plate, and into the combustion chamber for burning. The gas ports are not adjustable. Variation in capacity is accomplished by a variation in gas pressure.

Maintenance of the burner box and firing head is minimal, due to the simplicity of the parts and absence of small air or gas passages. An occasional inspection of the parts in contact with the flame will suffice. The flame retention plate must show no loss of metal or severe warping. If the heads of the retention plate mounting screws show loss of metal they must be replaced. Use only stainless steel screws.

Stainless nozzle sleeve must extend at least 1/2" beyond flame retention plate.

If the burner mounting flange or adjacent furnace wall show signs of overheating, check the tightness of the burner mounting. The burner is intended to be sealed into the boiler opening both at the face and at the mounting flange as shown in Figure 4, to prevent blow-back of hot flue products around the nozzle and flange.

---

## *IX Pilot and Flame Sensor*

The pilot is of the premix, blast type. Blower air is diverted from the blower housing through an air orifice into the pilot mixing tee mounted on the burner back plate, where the proper amount of gas is added through the pilot orifice. Both orifices are located at the end of their own respective tubes in brass fittings leading into the mixing tee. The gas/air mixture is then discharged through the heat resistant alloy flame retention pilot tip.

**The spark rod is located on the center line of the pilot and is arranged to arc to the inside of the central port. Spark current is supplied by a spark generator to ignite pilot gas.**

The pilot regulator is factory set of an outlet pressure of 3 -1/2" W.C. for NATURAL gas and PROPANE, which will be suitable for average conditions. Pressure can be varied to suit particular job conditions. Do not increase orifice sizes indiscriminately. Pilot troubles may be introduced by causing the pilot to float and lose contact with the flamerod or flame grounding area. Adjust the pilot per paragraph 7 of Section VIII-Initial Start-Up.

Service of the pilot will generally consist only of inspection and cleaning. Check that the pilot tip ports, air tube and mixing tee are free of lint and dirt and that the pilot tip is free of corrosion. Make sure that the air tube is re-inserted into the blower housing pilot air tube hole. The spark insulator and cable must be clean, dry and free from cracks and abrasions. Make spark gap settings per Figure 15.

Model	Wire Drill Sizes			Approx. Capacity BTU/Hr
	Air Orifice	Natural Pilot Orifice	Propane Pilot Orifice	
G56B(P)	#26 (.147)	#60 (.040)	#64 (.036)	3500
G57B(P)	#30 (.128)	#60 (.040)	#64 (.036)	3500
G58B(P)	#26 (.147)	#55 (.052)	#56 (.046)	5000
G69B(P)	#26 (.147)	#55 (.052)	#56 (.046)	5000

**Table 5: Pilot Specifications**

Proper operation of the flame safeguard depends on a reliable current flow through the flamerod, pilot flame, and flame grounding area. The flamerod must be free of any contact with conductive burner parts. The insulator must be clean, dry and free from cracks. While the rod is made of heat resistant alloy, it may eventually deteriorate at the point of flame contact and should be replaced if seriously corroded. See Figure 15 for the proper alignment of the flamerod. **DO NOT BEND THE FLAMEROD TO REDUCE THE DISTANCE FROM THE PILOT TIP.**

The blower functions to supply a constant and positive supply of air for complete combustion. Air volume is controlled by an adjustable shutter in the blower outlet. A small supply of air is diverted ahead of the shutter for the pilot and for operation of the blower air proving switch. No routine service is necessary on the blower other than an occasional cleaning of the blower wheel. If the blower wheel must be replaced, be sure to check the replacement for proper rotation. The concave sides of the blades must face the blower outlet, and rotation of the wheel must be toward the outlet. See Section VII # 6. The 3/4 HP single phase motor used on the G69B burner uses a motor switching relay to handle the motor load. All motors contain integral motor overload protection, usually manual, occasionally automatic reset.

Proof of blower operation is provided by a diaphragm air switch, which must close its contacts and maintain them closed when the blower is running. In case of malfunction the air switch should be replaced.

The gas pressure regulator is used to automatically reduce and maintain an constant gas pressure to the burner. To vary the outlet pressure, remove the seal cap for access to the adjusting screw. Turning the screw clockwise will increase outlet pressure, counter-clockwise will decrease outlet pressure. Maximum and minimum allowable gas pressures are shown in Table 1. Because these regulators are of the low pressure type with metal seats, leakage through the seat will cause outlet pressure to rise equal to inlet pressure during burner shutdown. Therefore do not subject the burner to inlet pressures above those listed (14" W.C.). For higher inlet pressures, See Section VI - PIPING for instruction on installing alternate regulators. The vent in the upper diaphragm case normally breathes air but should be vented to the outside for protection in the event of a punctured diaphragm. See Section VI - PIPING for proper venting procedures. Never connect the regulator to the diaphragm valve vent.

When the regulator is to be installed or replaced, take care not to distort the body casting. Apply wrench only to the heavy body section adjacent to the pipe thread.

**NOTE:** All burners are equipped with dual valves. Select the type you have and reference. Burner construction for special codes and/or insurance requirements such as Factory Mutual or Industrial Risk Insurers may require alternate construction. (Refer to Section XIV SPECIAL EQUIPMENT).

## *IX Pilot and flame Sensor Continued*

## *X Blower and Motor*

## *XI Gas Pressure Regulator*

## *XII Main Automatic Valves*

**1. Diaphragm Main Automatic Valve (Employed with Redundant Solenoid Valve.)** The Honeywell V88 diaphragm valve supplied on a UNIPOWER burners is of the slow opening, fast closing type and requires venting to the bleed connection on the burner box. Closing force combines a gas pressure differential, diaphragm weight and spring. When the controller is not calling for heat, the coil is de-energized. The plunger of the three way actuator is in the down position, so that the bleed is closed and the supply port is open. Gas flows to the top diaphragm, causing the gas pressure and spring to hold the valve closed.

With a call for heat, the flame safeguard energizes the coil. This pulls the plunger to the up position, opening the bleed valve and closing the supply port. The gas then bleeds off the top of the diaphragm, allowing the gas pressure below to lift the diaphragm and open the valve. When all the gas has bled off the top of the diaphragm, the valve is fully opened. In the event of a power failure during operation, the valve will close. Normal operation will resume upon restoration of power. For general service, tests for gas tightness and proper operation will suffice. If leakage is observed, replace valve.

If the valve will not open, make sure that normal gas pressure is available at the valve, the bleed line is unobstructed, and power is available at the terminals. If the valve fails to close, make sure power is off at the terminals and gas flow is in the direction of the arrow on the valve body. When a malfunction is found to be caused by the valve operator head, the entire valve must be replaced.

**2. Redundant Solenoid Gas Safety Valve Required Construction)** Unipower burners feature a redundant solenoid gas safety valve. This valve is a On-Off (2 position) valve. When the valve operator is electrically energized, a plunger lifts the valve disk off the valve seat, allowing gas to flow. When the current is broken the valve closes. It will normally require no service. If the operator malfunctions or the valve leaks replace the entire valve. After replacement check for leakage.

**⚠ WARNING: Explosion hazard. Do not use this device if it gets wet. It can malfunction and cause serious injury or death. Replace any device that has been wet.**

### **Prepurge S8670J**

When power is applied to L1 and L2 through a safety and operating control, the combustion air blower starts, once the air proving switch closes and proves blower operation, energizes the S8670J, and initiates a 30 second delay to allow system prepurge. After a 30 second prepurge, the 15 second trial for pilot ignition sequence begins.

### **Trial for Pilot Ignition**

On a "call for heat" and after 30 second prepurge, the module energizes the spark source and the pilot valve relay simultaneously. The pilot valve opens, allowing gas to flow to the pilot burner during the 15 second ignition trial time. The spark lights the pilot flame when pilot gas is present. A flame rectification circuit confirms the presence of the pilot flame, shuts off the spark source, and energizes the main valve relay.

### **Main Burner Operation**

When the main valve opens, gas flows to the main burner where it is lit by the pilot flame. There is a 2 second flame stabilization period as the main valve opens. The system is now in the run mode with the presence of the pilot flame continuously monitored by the flame rectification circuit. If the pilot flame goes out, or pilot flame signal drops below 1.1micro amps, the control senses loss of pilot flame and shuts off both the pilot valve relay and the main valve relay.

The control has two LEDs; one for flame sensing and one for system status:

- . Flame LED (Yellow)
- . Indicates flame presence and strength.
- . Status LED (Green)
- . Indicates system operation status and error conditions.

### **FAILED TRIAL FOR PILOT IGNITION S8670J**

If pilot flame is not lit and sensed before the end of the 15 second trial for ignition time, the control shuts off the pilot valve (100% shutoff) and goes to lockout. Or if proof of flame is lost during burner run cycle the system will retry once, if pilot flame is not proven within the 15 second trial for ignition time, the control shuts off the pilot valve relay and lockout. The control remains in lockout until power is cycled by the system thermostat or removing and restoring system power.

For operation characteristics, maintenance, service procedures, and LED codes refer to manufacturer's literature provided.

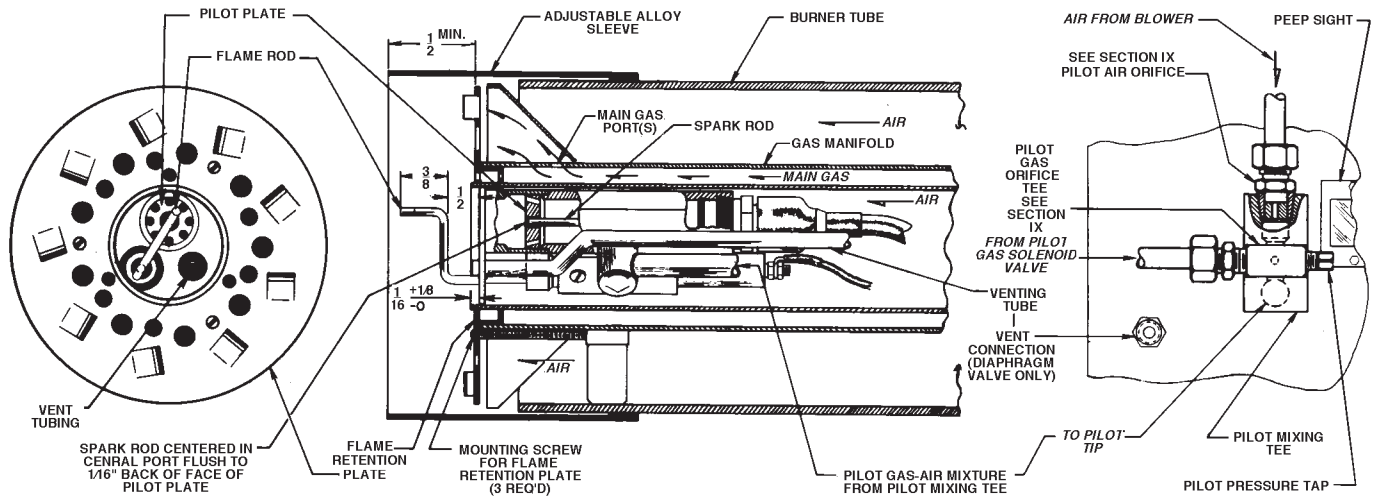

Figure 13 - Drawer Assembly

Special equipment, either factory or field installed, can cause variations in the procedures and descriptions given in this manual. Generally, any burner ordered with special factory installed equipment will be supplied with the appropriate wiring diagram and related instruction manuals from the special equipment manufacturer. Consult these manuals to identify any differences in construction, operation, and testing. Field installed special equipment is the responsibility of the installing contractor.

For example, when a high/low gas pressure switch is used, the high gas pressure setting must be higher than the maximum manifold pressure during initial start-up and the low pressure setting must be set below the normal minimum inlet pressure to prevent nuisance shutdowns during the start-up procedure.

After the burner is started, the low pressure setting should be raised until the burner shuts off. Reduce the setting and set the low pressure switch to restart the burner. Reduce the high pressure setting until the burner shuts off. Then raise the setting slightly and reset the high pressure switch to restart the burner. Do not make the adjustments too close to trip points or nuisance shut downs may occur. Any time the burner gas supply is shut off with the main manual valve, the low pressure switch will require resetting.

If any doubt exists concerning burner operation when special equipment is involved, contact the installing contractor or MIDCO INTERNATIONAL INC. (front cover).

**XIV Special Equipment  
(OEM Versions)**

# Trouble Chart

## *XV Trouble Chart*

## **Trouble Chart**

Make sure the thermostat and operating controls are calling for heat. Defective wiring or loose connecting can simulate the component defects outlined below. Check associated wiring before replacing a component.

### **ELECTRICAL AND FLAME CHECKS MUST BE MADE IN THE ORDER LISTED**

#### *1 - Motor Fails*

- A. No power to flame safeguard.
- B. Flame safeguard locked out.
- C. Defective flame safeguard.
- D. Defective motor relay.
- E. Motor overload "out".

#### *2 - Motor Fails to Start, Flame Safeguard Energized*

- A. Motor overload "out."
- B. Defective motor.
- C. Defective flame safeguard.

#### *3 - Motor Runs Continuously, No Lighting Attempt*

- A. Defective air switch.
- B. No air pressure at air switch.
- C. Defective flame safeguard.

#### *4 - Pilot Does Not Light, Flame Safeguard Locks Out*

- A. No pilot gas.
- B. Low pilot gas pressure.
- C. Defective pilot gas regulator.
- D. Misadjusted pilot regulator.
- E. Blocked pilot regulator vent.
- F. Defective pilot solenoid valve.
- G. Defective spark electrode.
- H. Misadjusted spark electrode.
- I. Defective spark cable.
- J. Clogged or incorrect pilot orifice.
- K. Defective pilot tip.
- L. Excess pilot air.
- M. Air orifice missing.
- N. Clogged pilot air tube.
- O. Defective flame safeguard.

#### *5 - Pilot Lights, Flame Safeguard Locks Out*

- A. Poor flame signal.
- B. Poor pilot flame.
- C. Misadjusted pilot regulator.
- D. Low gas pressure.
- E. No pilot air (see above).
- F. Excess pilot air (see above).
- G. Defective pilot tip.
- H. Defective flamerod wire.
- I. Defective or misadjusted flamerod.
- J. Defective flame safeguard.

#### *6 - Pilot Lights, No Lockout on Flame Safeguard, No Main Gas*

- A. Low gas pressure.
- B. Misadjusted main regulator.
- C. Blocked regulator vent.
- D. Defective main regulator.
- E. No power at main valve(s).
- F. Blocked main valve bleed line (If equipped).
- G. Defective main valve(s).
- H. Closed test cock.
- I. Input adjuster closed.
- J. Defective flame safeguard.



- 7 - Main Flame Lights, But Goes Out, Pilot Relights**
- A. Poor pilot.
  - B. Pilot gas pressure drops severely when main gas valve opens.
- 8 - Short Main Flame**
- A. Too little gas.
  - B. Low gas pressure.
  - C. Defective main regulator.
  - D. Misadjusted main regulator.
  - E. Too much air.
  - F. Partially closed test cock.
- 9 - Long, Hazy Flame**
- A. Too much gas.
  - B. High gas pressure.
  - C. Defective main regulator.
  - D. Misadjusted main regulator.
  - E. Misadjusted input adjuster.
  - F. Too little air.
  - G. Dirty blower wheel.
- 10 - Main Valve(s) Fails to Shut Off or Leaks**
- A. Defective valve(s).
  - B. Defective valve actuator.
  - C. Dirty valve seat.
- 11 - Motor Overload Frequently Trips Out**
- A. Low voltage.
  - B. Spasmodic start.
  - C. Defective motor.
  - D. High ambient temperature.
- 12 - Flame Safeguard Needs Frequent Resetting**
- A. See 4 above.
  - B. See 5 above.
  - C. See 6 above.

**NOTE:** Some of the probable causes listed above apply only to certain models as indicated, therefore some may not apply to your particular case.

---

