

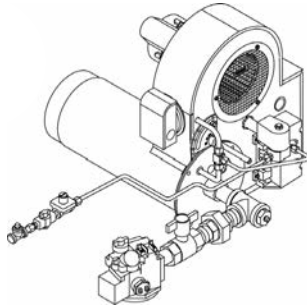

Midco[®]
INTERNATIONAL



Economite RE6700B / RE6850 / RE6850B Gas Burners

In the United States, Installation must conform with local codes or, in the absence of local codes, with Installation of the **National Fuel Gas Code, ANSI Z223.1-latest edition**, from the American National Standard Institute. Further reference should be made to the recommendation of your fuel supplier.

In Canada, Installation must conform with local codes or, in the absence of local codes, with **Installation Codes for Gas Burning Appliances and Equipment, CGA Standard CAN/CGA 1B-149**. Further reference should be made to the recommendation of your fuel supplier.

⚠ WARNING: Additions, changes, conversions, and service must be performed by an authorized MIDCO representative, service agency, or the fuel supplier. Use only MIDCO specified and approved parts.

INSTALLER: Inform and demonstrate to the user the correct operation and maintenance of the gas utilization equipment. Inform the user of the hazards of storing flammable liquids and vapors in the vicinity of this gas utilization equipment and remove such hazards. Affix this manual and associated literature adjacent to the burner. **CODE COMPLIANCE IS THE SOLE RESPONSIBILITY OF THE INSTALLER.**

USER: Retain this manual for future reference. If other than routine service or maintenance as described in this manual and associated literature is required, contact a qualified service agency. **DO NOT ATTEMPT REPAIRS.** An inadvertent service error could result in a dangerous condition.

⚠ WARNING: If the information in these instructions is not followed exactly, a fire or explosion may result, causing property damage, personal injury or death.

Do not store or use gasoline or other flammable vapors and liquids in the vicinity of this or any other appliance.

WHAT TO DO IF YOU SMELL GAS:

- ◆ Do not try to light any appliance.
- ◆ Do not touch any electrical switch; do not use any phone in your building.
- ◆ Immediately phone your gas supplier from another building. Follow the gas supplier's instructions. If you cannot reach your gas supplier call the fire department.

Installation and service must be performed by a qualified installer, service agency or the gas supplier.

BURNER MODEL _____

BILL OF MAT'L
NUMBER _____

SERIAL NUMBER # _____

WIRING DIAGRAM _____

FOR SERVICE CONTACT:

Name _____

Address _____

Phone _____

Date of Installation _____

SAFETY INFORMATION TERMS: The following terms are used to identify hazards, safety precaution of special notations and have standard meanings throughout this manual. They are printed in all capital letters using a bold type face as shown below, and preceded by the exclamation mark symbol. When you see the safety alert symbol and one of the safety information terms as shown below, be aware of the hazard potential.

DANGER: Identifies the most serious hazards which **will** result in severe personal injury or death.

WARNING: Signifies a hazard that **could** result in personal injury or death.

CAUTION: Identifies unsafe practices which would result in minor personal injury or product and property damage.



Midco International Inc.
4140 West Victoria St. - Chicago, Illinois 60646
tel 773.604.8700 fax 773.604.4070
web www.midcointernational.com

Quality Designed for Proven Performance

e-mail sales@midcointernational.com



1007
8471 45
Printed in U.S.A.

Specifications 1

The **ECONOMITE Models RE6700B, RE6850 and RE6850B** burners with intermittent spark ignited pilot are adaptable to most gas utilization equipment, including gravity and forced circulation furnaces, boilers and hot water heaters. They are particularly recommended for firing horizontal or downdraft equipment since no draft is required to maintain a pilot. Power burner design makes them perfectly suited for oil burner replacement, including rooftop and industrial applications.

AIR DELIVERY (Approximate Air Delivery at Zero Draft)

RE 6700B	RE 6850	RE 6850B
146SCFM ²	180SCFM ²	180SCFM ²

FIRING RATE (NATURAL OR PROPANE)³

	RE 6700B	RE 6850	RE 6850B
MAX MBH ⁴	700	825	825
MIN MBH ⁴	275	275	275

GAS SUPPLY PRESSURE REQUIRED

NATURAL	6.0" to 14.0" W.C.
PROPANE	5.0" to 14.0" W.C.

TUBE DIAMETER.....6"

TUBE LENGTH.....9"

RECOMMENDED COMBUSTION CHAMBER SIZE (AT MAX. BTU/HR)

	RE6700	RE 6850	RE 6850B
WIDTH	15"	15"	15"
LENGTH	25"	30"	30"

ELECTRICAL SUPPLY.....120 VAC..... 60 Hertz⁵ 3.5 AMPS⁷

IGNITION CONTROL MODULE VOLTAGE 24 VAC, RE6700B / RE6850B

FLAME SAFETY....Electronic Flame Safety with Spark Ignited Pilot and 100% Shut-Off⁶
..... 120 VAC, RE6850

TABLE 1: Burner Specifications

- Standard burners are shipped as NATURAL gas models. Contact your Midco dealer for PROPANE gas burners.
- SCFM = Standard Cubic Feet / Minute.
- All Ratings Based on 1000 BTU/Cu. Ft. NATURAL, 2500 BTU/Cu. Ft. PROPANE at sea level. Derate burner for altitude over 2,000 feet by 4% for each 1,000 feet above sea level.
- 1 MBH = 1,000 BTU/hr.
- For 50 Hertz applications the RE6700, RE6700B, RE6850 and RE6850B will be derated by 20%. Contact the factory for details. NOTE: Burners rated for 50Hertz are not UL Listed.
- See Section XII of Operational Sequence.
- Inrush AMP draw us higher - if needed, consult the factory.

Part 1
Installation

I Ventilation

CAUTION: The **ECONOMITE Models RE6700B, RE6850 and RE6850B** burners are not intended for outdoor installation and must be protected from excessive moisture. Provide adequate clearance for service and proper operation.

If the former automatic oil burner gave trouble-free operation, it is probable that the heating plant area has sufficient infiltration of air for combustion and dilution of flue gases. **Nevertheless, the area must be checked.**

Open basement or utility areas of normal construction, without storm windows or tight doors, will generally allow sufficient air infiltration. However, if the heating plant is located in a tight or separate room, ventilation to an open area as described above will be required. Install two permanently open grills, each sized on the basis of one square inch free area per 1,000 BTU (but not less than 100 square inches) of the total input rating of all gas utilization equipment in the combined space. One grille should be located within 12 inches of the ceiling, the other within 12 inches of the floor.

If the heating plant is located in an area of unusually tight construction, or if an exhaust fan, kitchen ventilation system, clothes dryer and/or fireplace is installed in the building, provisions must be made for an outside air supply near the heating appliance area. Install permanently open grills sized at not less than one square inch free area per 4,000 BTU of burner input. When ventilating through horizontal ducts, grills should be sized at not less than one square inch free area per 2,000 BTU of burner input. In any case, the minimum dimension of rectangular air ducts shall not be less than 3 inches.

In Canada, for detailed ventilation requirements, refer to standard CAN 1-B149.1 or .2 and/or local codes.

Part 1 Installation Continued

II Preparation of the Gas Utilization Equipment

- Clean the gas utilization equipment combustion chamber, heat exchanger interior, and flue connections. Remove all adhering tars, scale, dirt and soot. Inspect for actual or potential leaks.
- Cement all joints, including those in the heating appliance base and around the door frames, to prevent leakage into, or out of the combustion chamber.
- The access or firing door should open easily to relieve pressure. If positive latches exist, they should be modified to permit easy opening; a spring loaded door holder is recommended.
- On all boilers, make certain the pressure relief safety valve is in good operating condition.

III Combustion Chamber

A combustion chamber liner is normally required to protect non-heat transfer surfaces and to provide a radiant bed for rapid heat transfer to the primary surfaces of the heat exchanger. In most cases the existing chamber liner can be used, if in good condition.

In the case of wet base boilers, where the entire firing chamber is comprised of heat exchange surfaces and no chamber liner was provided for oil firing, a liner is usually not required for the ECONOMITE. However, a liner or target wall may be necessary if the firing chamber is unusually short, in order to avoid excess flame contact on the heat exchanger walls or flueways.

If a built up chamber liner is required, use 2,300°F minimum insulating material.

The burner tube, must be sealed air tight into the combustion chamber opening with refractory material or with supplied ceramic fiber rope.

⚠ CAUTION: In no case should the burner tube be allowed to extend into the chamber proper.

⚠ WARNING: BURNER MUST BE MOUNTED IN ORIENTATION SHOWN IN FIGURES 1 AND 2. ANY OTHER MOUNTINGS MAY CAUSE A DANGEROUS CONDITION, AND WILL VOID BURNER WARRANTY AND AGENCY APPROVALS. NON-STANDARD ARRANGEMENTS MAY BE AVAILABLE FOR SOME MODELS. CONSULT FACTORY FOR DETAILS IF REQUIRED.

Before permanently setting the burner in place, check that the main burner and pilot ports are free of foreign materials, and also that the spark electrode assembly has not been damaged or displaced. See Figure 6.

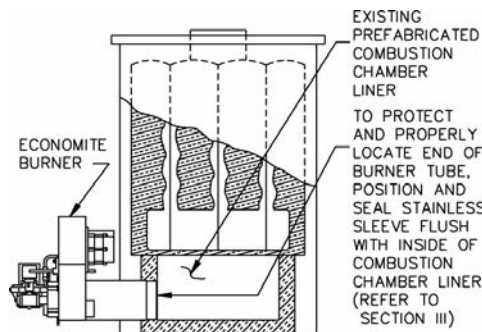

Figure 1: Dry Base Boiler with Combustion Chamber Liner (Warm Air Furnace Construction is Similar)

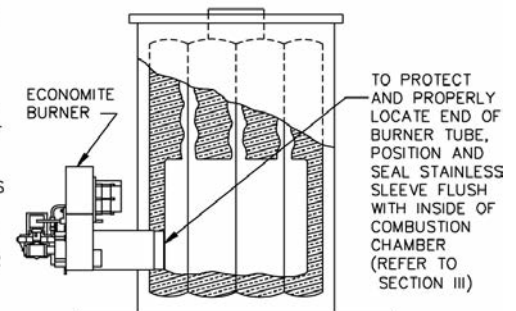

Figure 2: Wet Base Boiler with Unlined Combustion Chamber

IV Chimney, Vent Connector and Draft Control

⚠ WARNING: The chimney shall be inspected for unsafe conditions such as deteriorated masonry and excessive soot or other blockage or potential blockage. Installation must conform with local codes or in the absence of local codes with NFPA, ANSI Z223.1 latest edition.

⚠ WARNING: The vent connector shall not be connected to a chimney already venting solid fuel burning equipment, an incinerator or an open fireplace.

The Vent Connector shall be made of non-combustible, corrosion resistant material capable of withstanding the vent gas temperature produced by the gas utilization equipment and of sufficient thickness to withstand physical damage.

The Vent Connector shall be as short as possible. The entire length shall be readily accessible for inspection, cleaning, and replacement.

The length of horizontal uninsulated Vent Connector between the chimney and a single gas utilization equipment shall not exceed 75% of the height of the chimney above the connector, or 100% if the Vent Connector is insulated.

Part 1
Installation
Continued
IV Chimney, Vent
Connector and
Draft Control
Continued

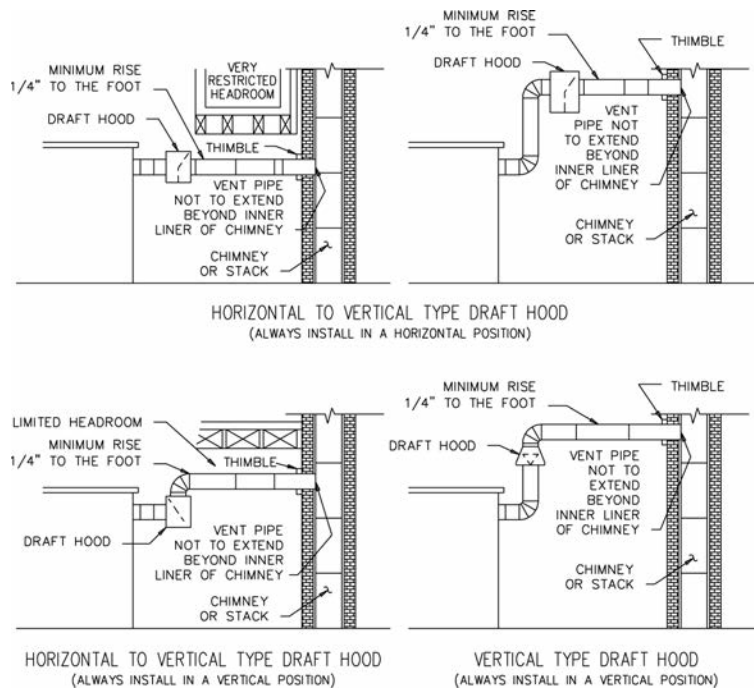

Note:
Figures 3 and 4 :
Copyright by
American Gas
Association.
Used by
permission of the
copyright holder.

Figure 3: Recommended Locations for Draft Hoods

- The Vent Connector shall be installed so as to avoid turns or other construction features which create excessive resistance to flow of vent gas. It shall be installed without any dips or sags and shall slope upward at least 1/4" per foot.
- A manually operated damper shall not be placed in the Vent Connector or chimney of any gas utilization equipment.
- The Vent Connector shall be firmly attached to draft hood outlets and flue collars. Joints between sections of connector piping shall be fastened by sheet-metal screws or other approved means. The Vent Connector shall be supported for the design and weight of the material employed to maintain clearance and prevent physical damage and separation of joints.
- A draft hood or a barometric draft regulator shall be installed in the same room or enclosure as the equipment in such a manner as to prevent any difference in the pressure between the hood or regulator and the combustion air supply (see Figures 3 and 4). In no case shall the relief opening of the draft hood or barometric draft regulator be located at a point lower than the top of the highest flue passage in the equipment.

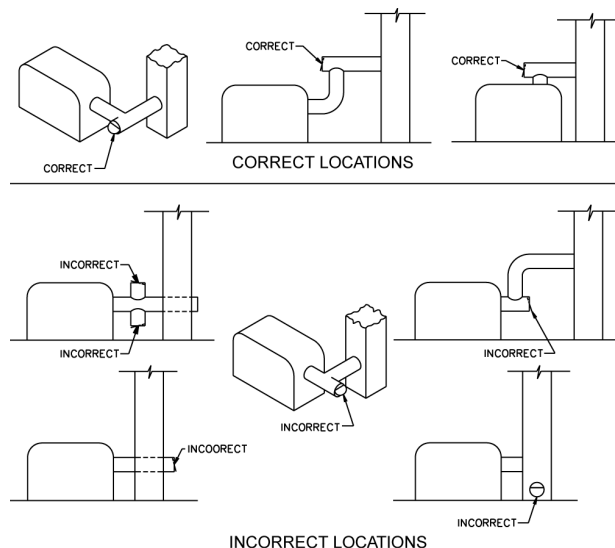

Note: Figures 3 and 4 :
Copyright by American
Gas Association.
Used by permission of
the copyright holder.

Figure 4: Location for Barometric Draft Regulators

Part 1 Installation Continued

- Gas utilization equipment requiring controlled draft may be equipped with a listed double acting barometric draft regulator, if approved by local codes (see Figure 4).
- A device which will automatically shut off gas to the burner in the event of sustained backdraft is required. It shall be of the listed manual reset type and installed and adjusted by a qualified service technician in accordance with the manufacturer's instructions.
- Refer to gas utilization equipment manufacturer for recommended vent connection requirements.

V Electrical

⚠ CAUTION: Refer to wiring diagram located on the inside of the burner housing cover or above wiring diagram. Before proceeding verify burner model number for correct wiring diagram.

Installation wiring and grounding to the burner must conform to local codes, or, in their absence in the **United States to National Electric Code, ANSI/NFPA No. 70** latest edition; in **Canada, to Canadian Electrical Code Part 1, CSA Standard C22.1**

- Use copper wire not less than 14 gage for line voltage wiring. Hook up to a dedicated line with an on-off disconnect switch and a minimum 10 Amp breaker.
- The frame of the burner should be well grounded. Normally the piping and/or electric conduit will provide sufficient grounding. However, a ground lug is located in control box for positive grounding where insulated pipe couplings are used or where any doubt exists regarding grounding sufficiency.
- Confirm that the polarity is correct—hot wire to strip terminal L1, neutral L2—and that the neutral line is not subject to induced low voltage (check L2 to earth ground) from other equipment, as that can cause the Ignition Control Module to malfunction.
- Each installation must include suitable limit control(s). Existing oil burner combination operating and limit controls are normally NOT SUITABLE for gas burner use.
- Connect motors used on forced air furnace fans or boiler pumps to a combination limit control and switch.
- Set the thermostat heat anticipator for the total current draw handled by the thermostat. The current draw of the ECONOMITE 24V operating circuit is 0.9 amps.

⚠ CAUTION: Label all wires prior to disconnection when servicing controls. Wiring errors can cause improper and dangerous operation. Verify proper operation after servicing.

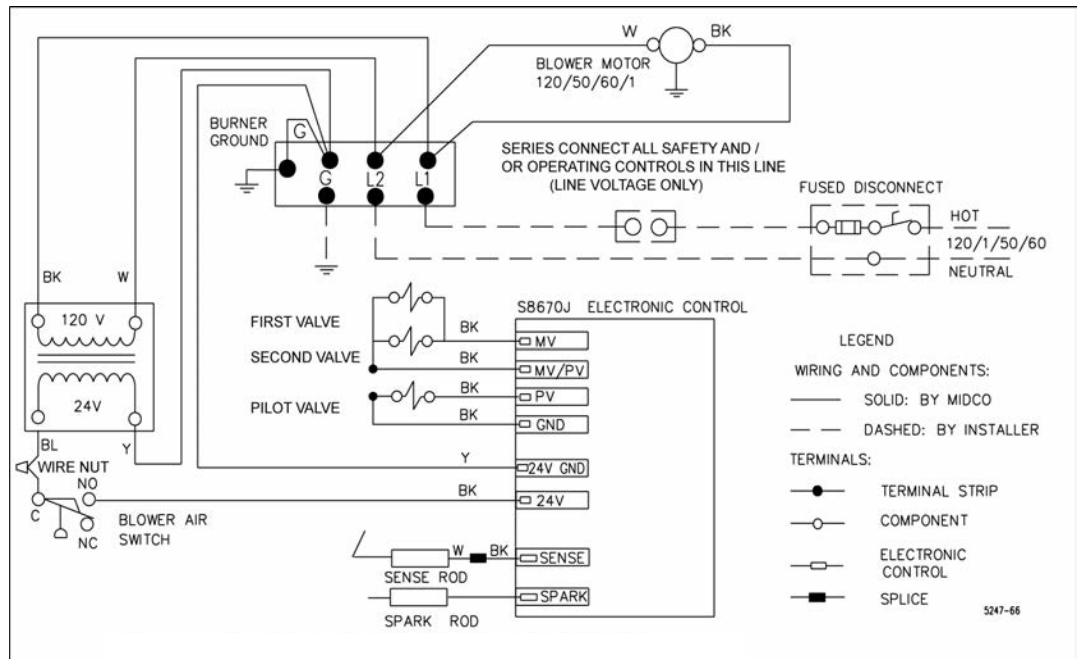

Wiring Diagram for RE6700B and RE6850B - 24V

Part 1 Installation Continued

V

Electrical Continued

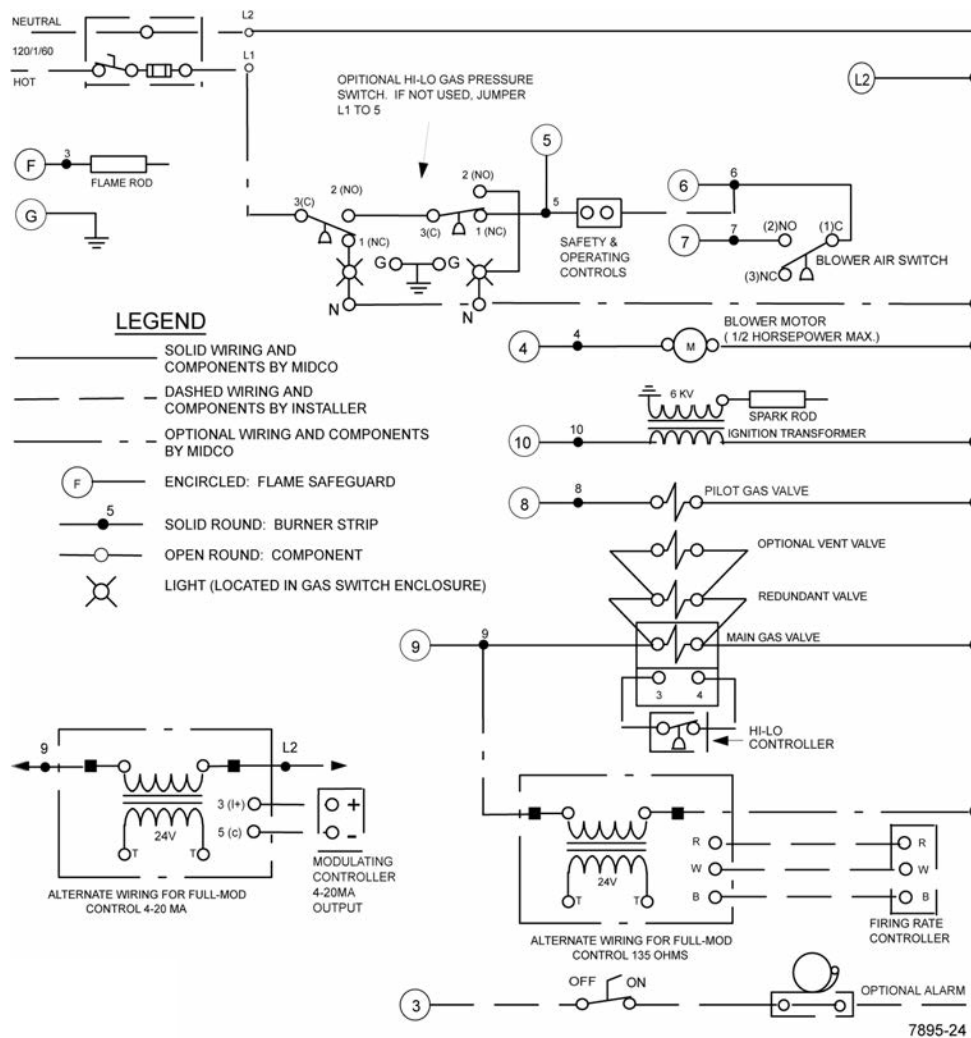

Wiring Diagram for RE6850 - 120V

VI

Piping



CAUTION: The available gas pressure should be within the limits shown in SPECIFICATIONS section. Excessive pressure may damage electric valves, regulators and manual valves. If the supply pressure exceeds the 14.0"W.C. maximum, a suitable high pressure regulator must be installed between the Main Manual Shut-Off Valve and burner shut-off valve as shown in Figure 5.

Pipe Size	Type of Gas	Approximate Capacity -MBH				
		Pipe Length				
		10	20	40	75	100
3/4	Natural	200	150			
3/4	Propane	590	400	275	190	160
1	Natural	400	275	200	150	
1	Propane	1075	730	500	360	300
1 1/4	Natural	900	600	450	325	275
1 1/4	Propane			1040	750	630
1 1/2	Natural		900	650	475	400
1 1/2	Propane					975

Capacities shown are for a total pressure drop of 0.3"W.C. For 0.5"W.C. pressure drop, multiply capacity shown by 1.3. Propane capacities shown are for a total pressure drop of 0.5" W.C. For higher permissible pressure drops, consult your gas supplier.

Table 2: Schedule 40 NPT
Pipe-Capacity Chart

Part 1
Installation
Continued
VI Piping
Continued

- The burner gas supply piping should branch off from the main line as close to the gas meter as possible. Do not connect to the bottom of a horizontal section. Use new black pipe and malleable fittings free of cutting and threading burrs or defects.
- Provide a sediment trap, union and 1/8" pressure tap in piping close to burner as shown in Figure 5.
- Use pipe joint compound approved for use with Liquid Petroleum Gases.
- Piping must also comply with your local codes.
- To obtain the maximum firing rate of the burner, the gas supply piping must be sized to provide a minimum of 6.0"W.C. pressure to the inlet of the upstream automatic safety shut-off valve when the burner and all other gas utilization equipment are on. The pilot regulator can be mounted in any position, the main regulator, if equipped, should be mounted upright and in a horizontal run of pipe.

⚠ CAUTION: Because it is difficult to accurately control pressure during supply pipe leak testing, it is recommended that all low pressure (14.0"W.C. max.) components, both main and pilot, be disconnected during testing. Exposing low pressure regulators and valves, including manual valves, to pressures over 1/2 PSIG (14.0"W.C.) will cause damage and void all warranties.

**⚠ DANGER: Explosion hazard.
Do not use oxygen for pressure testing.
An explosion could occur during initial start up.**

- If the burner piping must be rearranged because of space limitation, be sure to carry out the general arrangement shown in Figure 5. Refer to valve and regulator manufacturers specifications for acceptable mounting orientation.
- Run full size pipe or tubing from regulator vent openings to outside of building. Provide no traps in the vent lines and terminate away from all doors and windows; also make provisions for keeping rain and foreign objects from entering the vent piping.
- When high supply gas pressure is encountered, as in the case in many industrial plants, the gas line size can be reduced to allow for a greater pressure drop; however, the size must be sufficient to deliver burner rating pressure.

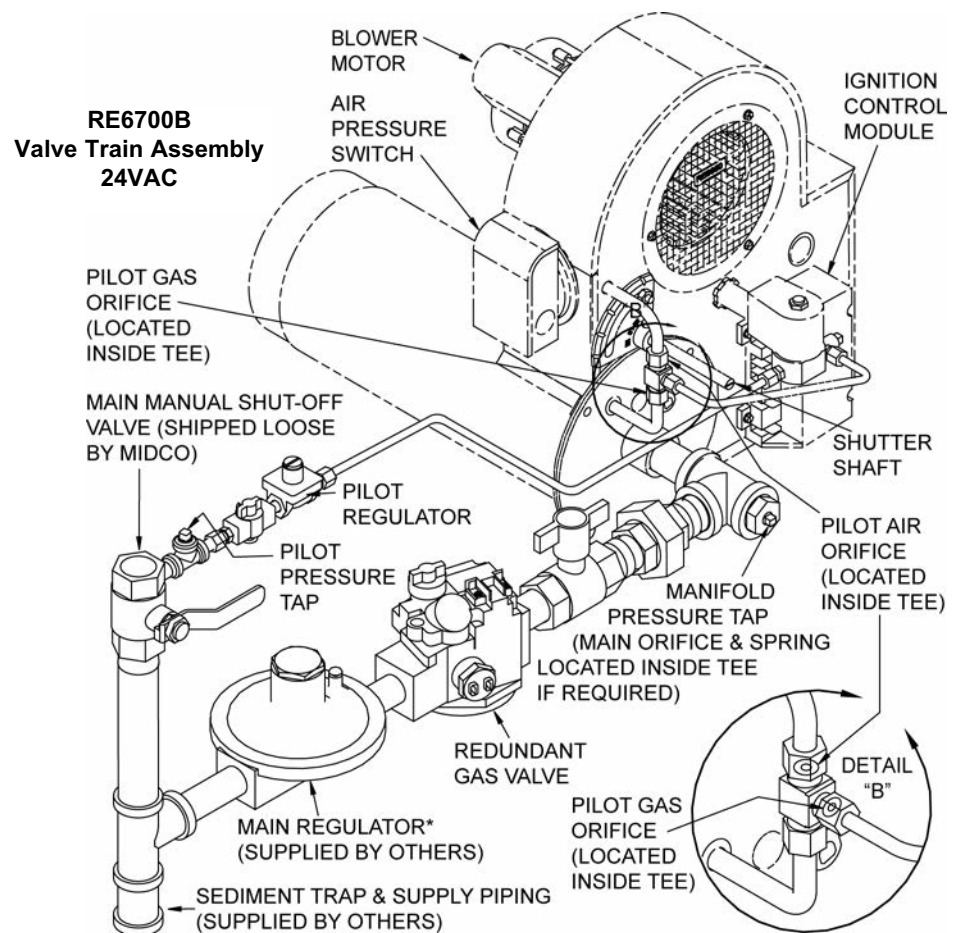

Figure 5: Piping Diagram for RE6700B - 24V

Part 1
Installation
Continued
Piping
Continued

RE6850
UL, Valve Train Assembly
120VAC

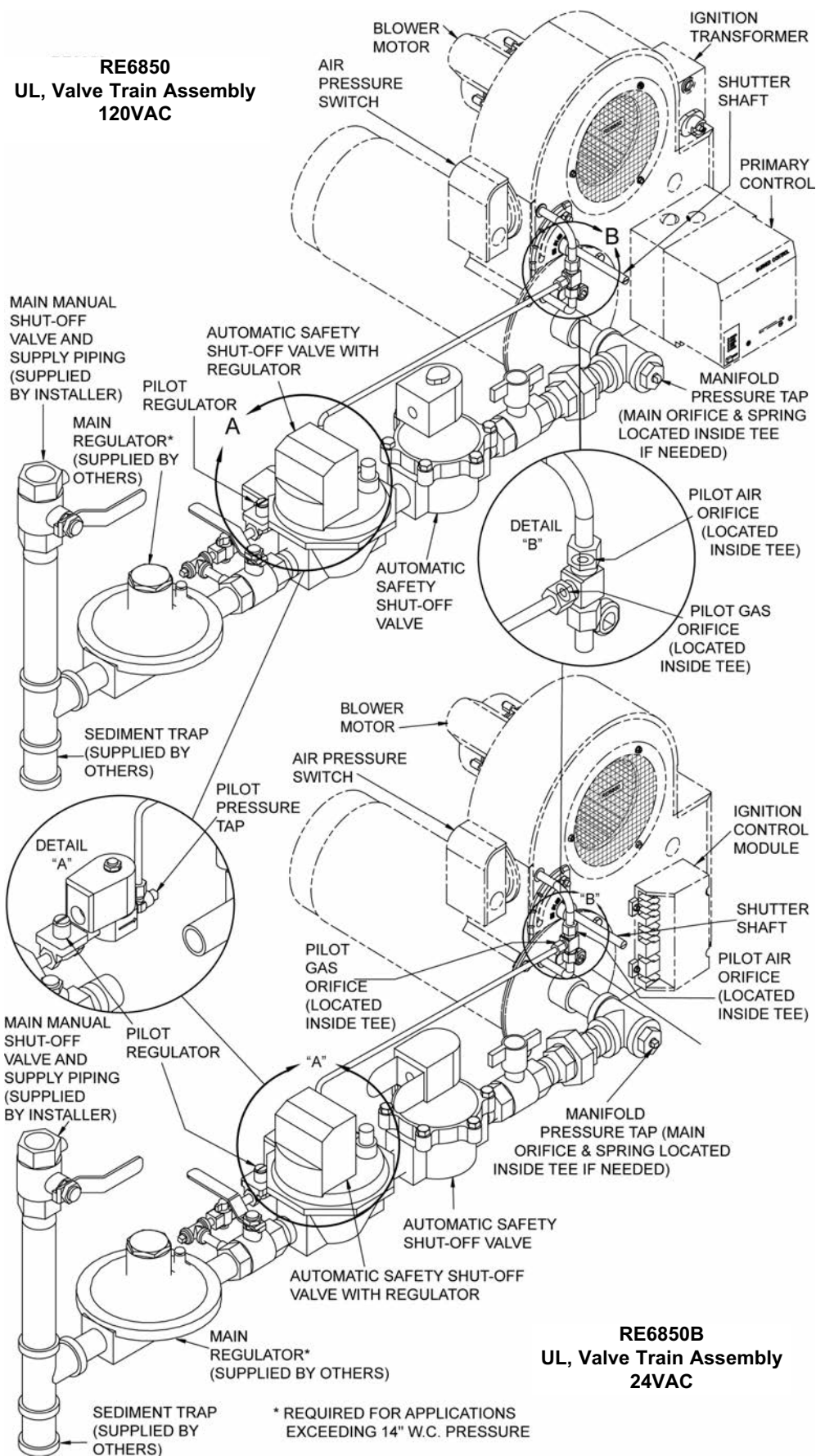

Figure 5 (Cont.): Piping Diagram for RE6850 - 120 V and RE6850 B - 24V

Part 1
Installation
Continued
VI Piping
Continued

⚠ CAUTION: High gas pressure supply lines require the proper pressure reducing regulators. Install a high pressure regulator of the Tight Shut-Off type upstream of the low pressure regulator. Sized for main gas input, and suitable for the minimum flow regulating capacity of the pilot.

- The high pressure regulator must be adjustable to 14" W.C. outlet pressure.
- When the gas supply line is about to be put into service it must be tested to insure that it is gas tight. Use air or inert gas under pressure and test with soap and water to locate leaks.
- Before gas is turned onto the system, a check must be made to see that there are no open fittings and to make sure the burner main and pilot manual valves are closed.
- After checking for leaks, purge the gas line up to the burner inlet. Purging the air from the gas supply line at this step will expedite the first light-off.

NOTE: If there is more than 1.0" W.C. differential in the inlet pressure to the burner compared to when all other gas utilization equipment are off, refer to Section VI.

VII Main Gas
Input Selection

Burners are approved for use with NATURAL gas or PROPANE gas and should be used only with the gas specified on the rating plate.

- The gas input should be set at the heating rate determined by the building heat loss and/or heating plant survey, but not exceeding the rated maximum input of the gas utilization equipment or Economite burner.
- For orifice selections and gas pressure settings refer to Table 3

VIII Initial Start-
up /Adjustment

⚠ WARNING: Ignition is automatic. Make spark observations into combustion chamber only with Main and Pilot Manual Shut-Off Valves closed. Confirm that gas utilization equipment does not contain any accumulated gases. Purge as described in step 3 below.

⚠ CAUTION: Cover plates, guards, and enclosures must be maintained in place at all times except during maintenance and service.

1. Check the burner piping and valves for gas leaks by applying a weak liquid soap solution to unions and joints with the gas supply on. Leakage will be indicated by the appearance of soap bubbles. Locate and correct all gas leaks before proceeding.

⚠ WARNING: DO NOT USE OPEN FLAME.

2. Purging the air from the gas supply line at this step will expedite first light-off.
IMPORTANT: Purge outside the building. Do not purge into the gas utilization equipment.
3. To purge the gas utilization equipment and chimney of any accumulated gases, turn main Manual Gas Cock **OFF**, close Pilot Manual Shut-Off Valve, turn burner power on, and set operating control to **ON** or thermostat to call for heat. Let the blower run long enough to accomplish four combustion chamber volume air changes, but not less than five minutes.

⚠ CAUTION: Make sure that the capacity range of the burner, manifold pressure, and the combustion air shutter setting are suitable for capacity rating of the gas utilization equipment. Refer to Section VIII and Table 3.

4. **RESET** the 24 volt ignition Control Module by setting the operating control to **OFF** or the thermostat below room temperature for at least 30 seconds. **RESET** the 120 volt RM7895 control by pushing its reset button. See Section XII.
5. Confirm that Main and Pilot Manual Shut-Off Valves are open. Turn main Manual Gas Cock **ON**.
6. Turn operating control to **ON** or set thermostat above room temperature. After the pre-purge is complete, the pilot should ignite. Whenever the burner pilot fails to light during the ignition trial, or if the flame is lost during the burner run and is not reestablished within 15 seconds after the pre-purge, the ignition system will shut off the Automatic Safety Shut-off Valves and **LOCK OUT**. **RESET** the 24 volt ignition Control Module by setting the operating control to **OFF** or the thermostat below room temperature for at least 30 seconds. **RESET** the 120 volt RM7895 control by pushing its reset button. If burner still fails to light, turn it off and repeat from step 4 above. Then if necessary, refer to the **TROUBLE CHART** to isolate the problem.

⚠ WARNING: Repeated unsuccessful attempts to light will result in accumulated gases in gas utilization equipment and chimney. To prevent these gases from reaching an explosive level, periodically purge the gas utilization equipment and chimney as described in step 3 above.

7. To make a preliminary setting of the burner input, determine the manifold gas pressure required from Table 3 and adjust the Main Gas Pressure Regulator accordingly. See Section XI.

Part 1
Installation
Continued
VIII Initial Start-
up /Adjustment
Continued

Natural Gas / Propane Gas Orifice Size and Pressure Settings

RE6850 & RE6850B		Natural Gas		Propane Gas		
Input MBTU/HR ₁	Orifice Size (Inches)	Letter Stamp	Manifold Pressure ("W.C)	Orifice Size (Inches)	Letter Stamp	Manifold Pressure ("W.C)
825	No Orifice	-	3.7	No Orifice	-	2.5
800	No Orifice	-	3.5	No Orifice	-	2.3
750	No Orifice	-	2.9	0.563"	H	2.7
700	No Orifice	-	2.5	0.563"	H	2.4
650	No Orifice	-	2.3	0.563"	H	2.1
600	0.563"	H	2.7	0.484"	O	2.2
550 *	0.563"	H	2.3	0.422"	F	2.4
500	0.484"	O	2.8	0.404"	P	2.3
450	0.484"	O	2.3	0.358"	J	2.5
400	0.422"	F	2.1	0.332"	K	2.2
350	0.358"	J	3.0	0.297"	L	2.5
300	0.358"	J	2.2	0.277"	N	2.4
275	0.332"	K	2.2	0.277"	N	2.0
RE6700B						
700	No Orifice	-	2.5	0.563	H	2.4
650	No Orifice	-	2.3	0.563	H	2.1
600	0.563"	H	2.7	0.484	O	2.2
550 *	0.563"	H	2.3	0.422	F	2.4
500	0.484"	O	2.8	0.404	P	2.3
450	0.484"	O	2.3	0.358	J	2.5
400	0.422"	F	2.1	0.332	K	2.2
350	0.358"	J	3.0	0.297	L	2.5
300	0.358"	J	2.2	0.277	N	2.4
275	0.332"	K	2.2	0.277	N	2.0

DATA FOR TABLES IS APPROXIMATE AND BASED ON "0" OVERFIRE PRESSURE AT SEA LEVEL

Note: Manifold Pressure settings are based on zero back pressure

- Adjust the main regulator to vary the manifold gas pressure and burner input within the range shown. Do not exceed pressure as listed in Table 3, under any circumstances. Use combustion readings (CO or O₂) to determine exact inputs.
 - If you need an orifice that is not included with the burner, drill out the provided 0.358 orifice (stamped J) to the required hole size as per chart above
 - Natural gas to LP gas conversion kits are available, consult factory.
- * Orifice size and approximate manifold gas pressure setting as shipped. Air shutter is set on mark 4.

Table 3: Capacity and Preliminary Gas Settings

- To determine the firing rate for NATURAL gas, accurately time test dial for the number of seconds for one revolution and use the following formula. All other gas utilization equipment must be off.

$$\frac{3600 \times \text{test dial size} \times \text{BTU value}}{\text{No. of seconds for one rev. test dial}} = \text{BTU/Hr.}$$

Then divide by 1,000 for MBH value.

Example:
$$\frac{3600 \times 1 \times 1000}{10} = 360,000 \text{ BTU/HR} = 360 \text{ MBH}$$

Part 1
Installation
Continued
VIII Initial Start-
up /Adjustment
Continued

9. Check the operation of the burner; start and stop it several times with the thermostat or operating control.
10. With the burner running, check the operation of all limit and associated controls.
11. Perform the following final adjustments for combustion and flue gas temperature. Take the flue gas samples and temperature immediately upstream of the draft control.
 - A. The flue gas temperature should be above 325°F but not exceeding 550°F. Excessive flue gas temperatures will result in low efficiencies. Low flue gas temperature may cause excessive condensation. Reset gas input, if necessary, to adjust stack temperature.
 - B. Make the final setting of the combustion air shutter by checking the flue gases with an **ORSAT** or similar combustion testing instrument. The carbon monoxide content should conform to local codes, or in their absence, to the level specified in the United States or Canadian Standard referenced on the front cover of this manual; and the carbon dioxide content should be approximately 9.5% for NATURAL or 12% for propane, or within the limits prescribed by local codes.
12. Check the draft control to make sure there is no spillage of flue products into the room.
13. **FILL OUT THE INSTALLATION ADJUSTMENT DATA TAG** and affix to the burner or gas utilization equipment.

NOTE: For subsequent normal starting and shut off procedure, refer to **CONSUMER INSTRUCTIONS**, located in part 3 of this manual, or to the instruction plate mounted on the burner.

Part 2
Service

PART 2 SERVICE

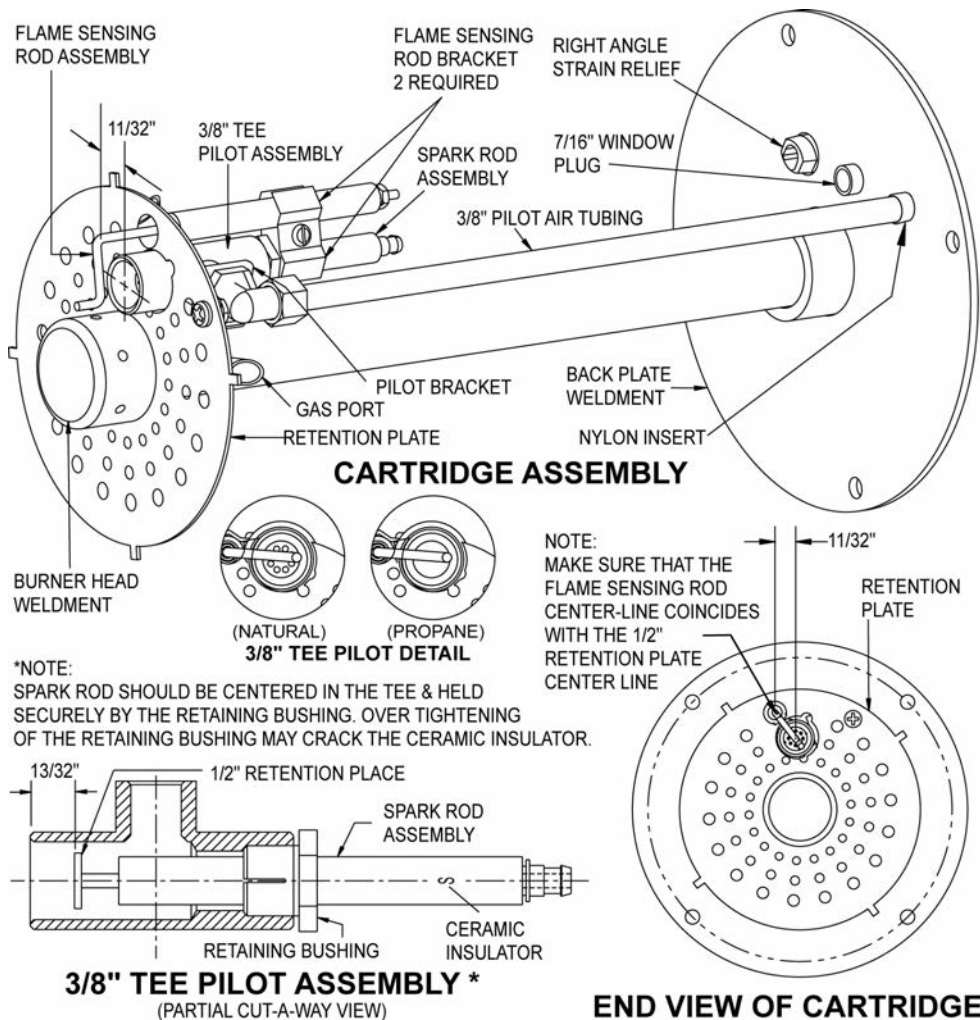

Figure 6 : General Assembly for RE6000 Series

Part 2
Service
Continued

⚠ DANGER: Do not tamper with the unit or controls. If trouble occurs contact the installing contractor, service agency, or fuel supplier. See front cover.

⚠ DANGER: Be sure that the main and pilot manual Shut-Off Valves are closed and the burner power supply is turned off before removing any parts for service.

⚠ CAUTION: Cover plates, guards, and enclosures must be maintained in place at all times except during maintenance and service.

Model	Gas Orifice Diameter #54 Wire Drill	Approx. Capacity BTU/Hr.	Pilot Gas Pressure	
			Natural	Propane
RE 6700	0.055"	6000	3.0"	2.5"
RE 6850	0.055"	6000	to	to
RE 6850B	0.055"	6000	4.5" W.C.	3.5" W.C.

Table 4: Pilot Specifications

The pilot is of the premix, blast type. The full force of blower air is brought into the mixing tube where the proper amount of gas is added through the pilot orifice. This mixture is discharged through the pilot. The mixture provides the flame that contacts the flame sensing rod and also ignites the main gas.

IX Pilot

⚠ CAUTION: Do not indiscriminately increase pilot orifice size. Pilot troubles are rarely cured in this manner and new troubles may be created.

- Under normal conditions, with a slight negative pressure in the combustion chamber, pilot operating pressures should be set as indicated in Table 4.
- Some conditions which may require a change from the normal setting include: extremely long tubing connections between the regulator and pilot solenoid, high negative or positive combustion chamber pressure, actual air shutter setting and altitude extremes.
- Do not subject the pilot to an inlet pressure over 14.0"W.C. See Section VI PIPING for high pressure gas.
- To adjust outlet pressure, remove the seal cap for access to the adjusting screw. Turning the screw clockwise will increase outlet pressure, counter clockwise will decrease outlet pressure.
- The spark rod for a natural gas burner is welded to a round 1/2" **perforated** retention plate. (The spark rod for a propane gas burner is welded to a round 1/2" **solid** retention plate.) The 1/2" retention plate is centered in the 3/8" Tee pilot and is positioned so the high tension voltage will arc to the inside of the 3/8" Tee pilot. (See Figure 6).
- The flame sensing rod must be positioned as shown in Figure 6 so that the controller will detect a proper flame.
- Both the spark and flame rods are current carrying conductors and, along with their connecting wires, must be kept free of contact with conductive metal parts of the burner. Rod insulators and wire insulators should be clean, dry and free of cracks.
- Both the spark and flame rods are made from heat resistant alloys and can be expected to have a long service life. They should be routinely inspected, however, for corrosion or loss of metal.
- The pilot air tubing must be kept free of kinks or inside obstructions and must be positioned per Figure 6, otherwise air flow could be reduced and adversely affect the pilot flame.

X Motor Blower Interlock

⚠ CAUTION: BEFORE SERVICING, mark with a scribe line or measure opening of air controlling shutter, so that it can be reset to its original position following servicing.

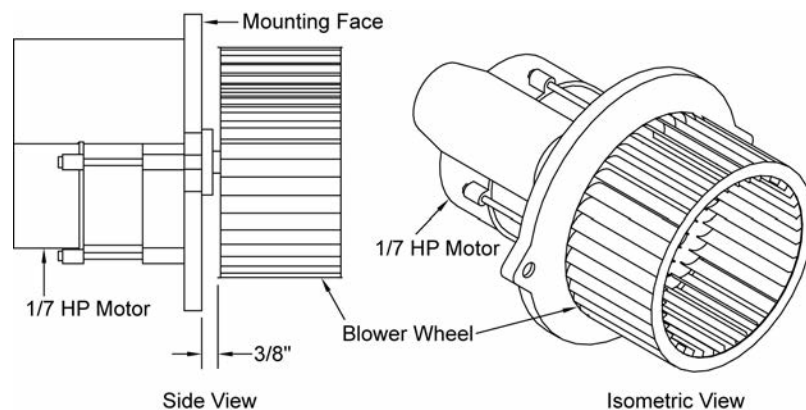

Figure 7: Motor / Blower Assembly

*Part 2
Service
Continued*

*X Motor Blower
Interlock
Continued*

- Cleaning of the blower wheel is usually the only service required. Need for cleaning is indicated if the character of the flame indicates a deficiency of air. Motor cooling air vents (if present) should also be cleaned at this time.
- The motor and wheel are removed as an assembly. Disconnect the motor wires from the motor terminal strip. Disconnect the motor conduit from the motor and remove the mounting bolts.
- The burner is equipped with a diaphragm type air pressure switch so as to prevent the burner from firing if the blower wheel is not running at its operating speed. When the motor is off there is no air pressure present to activate the pressure switch and in turn there is no power flow to the Ignition Control System.
- To make a specific test of the air pressure interlock switch circuit:
 1. Turn burner power **OFF**.
 2. Turn Manual Gas Cock **OFF**.
 3. Disconnect the motor wire from the terminal strip to keep the motor off.
 4. Turn burner power **ON** and set the operating control to **ON** or thermostat to call for heat. Verify there is 120VAC line voltage by using a multimeter. Check for 24V between the Ignition Control Module **24V** and **24V GND** terminals.
 - A. No voltage: Interlock circuit OK.
 - B. Voltage present: check that the switch is wired properly or check switch operation. Replace if switch tests bad.

XI Valve Train

- Should replacement or service be required, valve manufacturer's instructions must be followed as outlined in their information sheet.
- Outlet pressure settings must be checked while the gas is flowing.
- To adjust outlet pressure, remove the seal cap for access to the adjusting screw. Turning the screw clockwise will increase outlet pressure, counter clockwise will decrease outlet pressure.

*XII Sequence of
Operation*

- Prepurge S8670J
When power is applied to L1 and L2 through a safety and operating control, the combustion air blower starts, once the air proving switch closes and proves blower operation, energizes the S8670J, and initiates a 30 second delay to allow system prepurge. After a 30 second prepurge, the 15 second trial for pilot ignition sequence begins.
- Trial for Pilot Ignition
On a "call for heat" and after 30 second prepurge, the module energizes the spark source and the pilot valve relay simultaneously. The pilot valve opens, allowing gas to flow to the pilot burner during the 15 second ignition trial time. The spark lights the pilot flame when pilot gas is present. A flame rectification circuit confirms the presence of the pilot flame, shuts off the spark source, and energizes the main valve relay.
- Main Burner Operation
When the main valve opens, gas flows to the main burner where it is lit by the pilot flame. There is a 2 second flame stabilization period as the main valve opens. The system is now in the run mode with the presence of the pilot flame continuously monitored by the flame rectification circuit. If the pilot flame goes out, or pilot flame signal drops below 1.1micro amps, the control senses loss of pilot flame and shuts off both the pilot valve relay and the main valve relay.
- The control has two LEDs; one for flame sensing and one for system status:
 - . Flame LED (Yellow)
 - . Indicates flame presence and strength.
 - . Status LED (Green)
 - . Indicates system operation status and error conditions.
- FAILED TRIAL FOR PILOT IGNITION S8670J
If pilot flame is not lit and sensed before the end of the 15 second trial for ignition time, the control shuts off the pilot valve (100% shutoff) and goes to lockout. Or if proof of flame is lost during burner run cycle the system will retry once, if pilot flame is not proven within the 15 second trial for ignition time, the control shuts off the pilot valve relay and lockout. The control remains in lockout until power is cycled by the system thermostat or removing and restoring system power.
- For operation characteristics, maintenance, service procedures, and LED codes refer to manufacturer's literature provided.



WARNING: Explosion hazard. Do not use any electronic device if it gets wet. It can malfunction and cause serious injury or death. Replace any device that has been wet.

XIII S8670J Ignition Control Module

□ For operation characteristics, maintenance, and service procedures, refer to manufacturer's literature provided with burner.

XIV Primary Safety Control RM7895

□ The standard RE6850 burner is equipped with a Honeywell RM7895 microprocessor based burner control, employing a flame rectification system of flame detection. Burner construction for special codes and/or insurance requirements such as Factory Mutual or Industrial Risk Insurers (IRI) may require alternate controls. A safe start and run control sequence is provided with instantaneous response to presence or loss of flame signal. Flame failure response time is 3-seconds; Pilot Flame Establishing Period (PFEP) is field selectable from 4 or 10-seconds. The RM7895 features a pre-purge time (30-seconds for ON-OFF, 90-seconds for 2-Step or Modulating burners), and a plug-in amplifier. An airflow circuit is also field selectable to allow either lockout or recycle upon loss of airflow. Five LED's (light emitting diodes) are provided to display sequence information. Refer to the Honeywell RM7895 literature for detailed operating information, configuration requirements, testing, and service.

INITIATE SEQUENCE ("POWER" LED is lit)

□ The RM7895 enters the **INITIATE** sequence when it is powered. The **INITIATE** sequence lasts for ten seconds unless the voltage or frequency tolerances are not met (refer to Honeywell RM7895 literature for criteria). When tolerances are met, the **INITIATE** sequence will restart. If the conditions not corrected and the hold condition exists for four minutes, the RM7895 will lock-out. Causes for hold conditions in the **INITIATE** sequence are in the Honeywell RM7895 literature.

STANDBY ("POWER" LED is lit)

□ The RM7895 is idle in this state of sequencing. When the burner switch, limits, operating limit controls, and all microprocessor monitored circuits are in the correct state for the RM7895 to continue, sequencing will advance to PREPURGE.

PREPURGE ("POWER" LED is lit)

□ The RM7895 in this application features a prepurge time of 30-seconds for ON-OFF, 90-seconds for 2-Step or Modulating burners.

□ Once the **STANDBY** sequence has a "**CALL FOR HEAT**" input, normal start-up prepurge will be initiated.

A. The blower motor is powered to start the prepurge sequence.

B. The airflow interlock switch must close in ten seconds of prepurge or within the specified purge card timing. Otherwise a recycle to the beginning of prepurge or lockout will occur, depending on how the airflow switch selectable jumper is configured. Refer to Honeywell RM7895 literature for configuration requirements.

IGNITION TRIAL

1. PILOT FLAME ESTABLISHING PERIOD (PFEP)

A. The pilot valve and spark generator are energized.

B. Flame must be proven by the end of the 4 or 10-second PFEP to allow the sequence to continue. If flame is not proven by the end of PFEP, a safety shutdown occurs.

2. MAIN FLAME ESTABLISHING PERIOD (MFEP)

□ After the ignition trials, and with the presence of flame, the main valve is energized. ("MAIN" LED will be lit.) If a flame-out occurs, the RM7895 will lockout or recycle within 3-seconds, depending on "jumper" configuration. Refer to Honeywell literature for proper configuration.

□ The RM7895 is now in **RUN** mode and will remain in run mode until the controller input opens, indicating that the call for heat has been satisfied or a limit has opened. Once this occurs the RM7895 will sequence back to the **STANDBY** mode.

- Notes:**
1. During **STANDBY** and during RM7895 sequencing the "**POWER**" LED will blink every four seconds. This is normal.
 2. The "**ALARM**" LED will be lit in the event of any flame failure.
 3. To maintain proper operation of this device it **MUST** be electrically grounded. Refer to Honeywell RM7895 literature for criteria.

XV Special Equipment (OEM Versions)

□ Special equipment, either factory or contractor installed, may cause variation in the procedures and descriptions given in this manual.

□ Consult the OEM's manual to identify the differences in the information.

XVI Canadian Specifications

The major difference for the CUL version of the RE6700B / RE6850 / RE6850B is the French / English specification plate and the firing valve for the pilot line.

*Part 3
Maintenance*

PART 3 MAINTENANCE

Consumer Instructions

CONSUMER INSTRUCTIONS

- Keep the area around the burner clear and free of combustible material, gasoline or other flammable liquids or vapors. Do not obstruct burner air openings or ventilation grills for combustion air.
- The motor features permanently lubricated ball bearings and requires no maintenance.

⚠ WARNING: If any flame is observed when the burner is on standby, or if the ignition spark or valve operator is heard to come on before the motor reaches operating speed, immediately turn off the manual gas control and burner power. A dangerous condition has developed and must be corrected. CONTACT A QUALIFIED SERVICE TECHNICIAN FOR CLEANING, READJUSTMENT OR REPAIR.

- Check that the pilot ignition spark does not come on before the motor reaches operating speed. If it does, the air switch is defective and must be replaced. (See Section X, Motor / Blower Interlock).

Lighting Instructions

LIGHTING INSTRUCTIONS

1. SET OPERATING CONTROL TO **OFF** OR THERMOSTAT BELOW ROOM TEMPERATURE.
2. TURN MANUAL GAS COCK **ON**.
3. TURN BURNER POWER **ON**.
4. SET OPERATING CONTROL TO **ON** OR THERMOSTAT TO CALL FOR HEAT.
5. IF THE PILOT FLAME IS NOT PROVEN WITHIN 15 SECONDS, AFTER THE PRE-PURGE, THE CONTROLLER WILL SHUT OFF THE AUTOMATIC SAFETY SHUT-OFF VALVES AND LOCK OUT. IF THE PROOF OF FLAME IS LOST DURING BURNER RUN AND THE PILOT IS NOT RE-ESTABLISHED WITHIN 15 SECONDS AFTER THE PRE-PURGE, THE CONTROLLER WILL SHUT OFF THE AUTOMATIC SAFETY SHUT-OFF VALVES AND LOCKOUT. **RESET** THE 24 VOLT IGNITION CONTROL MODULE BY SETTING THE OPERATING CONTROL TO OFF OR THE THERMOSTAT BELOW ROOM TEMPERATURE FOR AT LEAST 30 SECONDS. **RESET** THE 120 VOLT RM7895 CONTROL BY PUSHING ITS RESET BUTTON.
6. REPEAT STEP 4 FOR RESTART.

TO SHUT OFF

1. TURN MANUAL GAS COCK **OFF**.
2. TURN BURNER POWER **OFF**.

SHOULD OVERHEATING OF THE APPLIANCE OCCUR

1. Shut off the manual gas control valve to the appliance.
2. **Do not** shut off the electrical supply power to the blower.

Part 3 Maintenance
Continued
Trouble Chart

TROUBLE CHART

Make sure the thermostat and operating controls are calling for heat.

⚠ CAUTION: If a test indicates an electrical component may be defective, before replacing it, make sure that its associated wiring is not at fault.

ELECTRICAL AND FLAME CHECKS MUST BE MADE IN THE ORDER LISTED BELOW.

I Motor Will Not Run or Motor Runs in Repeated Cycles

I. MOTOR WILL NOT RUN

- A. Confirm 120V between strip terminals **L1** and **L2** and verify the circuit polarity and electrical ground between strip terminal **L1** and burner Ground.
- B. Check for 120V between strip terminals **L1** and **L2**.
 - 1. No voltage, open circuit in operating controls.
 - 2. Voltage present, motor is defective.

II Motor Runs Continuously, But No Flame

II. MOTOR RUNS CONTINUOUSLY, PILOT WILL NOT LIGHT

- A. Confirm that ALL Main Manual Shut-Off Valves are in the **ON** position.
- B. After the pre-purge, if the pilot flame is not proven within the pilot flame re-establishing period, or if the proof of flame is lost during the burner run and the pilot is not re-established after the pre-purge, the Ignition Control Module will **lock out**. **RESET** the 24 volt ignition Control Module by setting the operating control to **OFF** or the thermostat below room temperature for at least 30 seconds. **RESET** the 120 volt RM7895 control by pushing its reset button. See Section XII.
- C. Clogged pilot orifice.
- D. Pilot regulator mis-adjusted or defective.
- E. Defective spark electrode, Ignition Control Module or Transformer for 120V.
- F. Defective high tension wire.
- G. Wrong pilot orifice.
- H. Defective pilot valve.
- I. Pilot air tube clogged.
- J. Incorrect spark gap.
- K. Pilot regulator vent clogged.
- L. Defective blower air switch.
- M. Step down transformer is defective, (if applicable).
- N. Insufficient pilot flame sensing signal.

III Pilot Lights, No Main Flame

III PILOT LIGHTS, NO MAIN FLAME

- A. Poor pilot flame adjustment.
- B. Clogged pilot air tube.
- C. Defective flame sensing rod or wire.
- D. Flame sensing rod mis-located.
- E. Pilot regulator vent clogged.
- F. Defective Ignition Control Module, if applicable.
- G. Defective main gas valve.
- H. Low gas pressure.
- I. Grossly mis-adjusted main gas and air mixture.
- J. Insufficient pilot flame sensing signal.

