

## BASO Shutoff Gas Valve Instructions for Midco Incinomite Burner - J83-DS

 **CAUTION:** Read and understand this service bulletin thoroughly before starting. Only a trained, experienced service technician should attempt this service procedure.

### BASCO Installation Instructions



BASO Gas Products LLC

Installation Instructions  
Issue Date

H91 Model Rev. B  
July 27, 2018

### H91 Model Rev. B Series Shutoff Gas Valve

**AVOID ERROR IN PARTS SELECTION.** When ordering use complete MIDCO Part Number and Description. Furnish Burner Model Number, Bill of Material Number and Serial Number (if available) from the specification plate found on the product.

**IMPORTANT:** Availability of parts as well as specifications are subject to change without notice. Please consult factory for item availability.

**SAFETY INFORMATION TERMS:** The following terms are used to identify hazards, safety precaution of special notations and have standard meanings throughout this manual. They are printed in all capital letters using a bold type face as shown below, and preceded by the exclamation mark symbol. When you see the safety alert symbol and one of the safety information terms as shown below, be aware of the hazard potential.



**DANGER:** Identifies the most serious hazards which will result in severe personal injury or death.  
**WARNING:** Signifies a hazard that could result in personal injury or death.  
**CAUTION:** Identifies unsafe practices which would result in minor personal injury or product and property damage.



Midco<sup>®</sup>  
INTERNATIONAL

Midco<sup>®</sup> International Inc.  
4140 West Victoria Street  
Chicago, Illinois 60646  
toll free 866.705.0514  
tel 773.604.8700  
fax 866.580.8700  
web [www.midcointernational.com](http://www.midcointernational.com)  
e-mail [sales@midcointernational.com](mailto:sales@midcointernational.com)



BASCO Gas Products LLC

Installation Instructions  
Issue Date

H91 Model Rev. B  
July 27, 2018

## H91 Model Rev. B Series Shutoff Gas Valve

### Applications

The H91 Series shutoff gas valve is an electrically operated gas valve that will open on a demand signal from a thermostat or other controlling device and automatically close when the signal is removed. Typical applications include heaters, wall furnaces, commercial cooking equipment, roof top makeup units and similar applications. The H91 Series can be used with natural gas and LP gas at pressures up to 0.5 psi. Its compact size permits installation in space restrictive applications.

### Installation

**IMPORTANT:** Only qualified personnel should install or service BASCO® Gas Products. These instructions are a guide for such personnel. Carefully follow all instructions in this document and all instructions for the appliance.

**IMPORTANT:** Make all gas installations in accordance with applicable local, national, and regional regulations.



**CAUTION: Risk of Electric Shock.** Disconnect power supply before making electrical connections to avoid electric shock.



**WARNING: Risk of Explosion or Fire.** Shut off the gas supply at the main manual shutoff valve before installing or servicing the H91 Series. Failure to shut off the gas supply can result in the release of gas during installation or servicing, which can lead to an explosion or fire, and may result in severe personal injury or death.



**WARNING: Risk of Explosion, Fire, or Electric Shock.** Label all wires before they are disconnected when replacing or servicing the H91 Series. Wiring errors can cause improper or dangerous operation and may result in an explosion, fire, or electric shock leading to severe personal injury or death.

**IMPORTANT:** Verify that the valve is installed only in applications where the specified maximum ambient (surface) temperature and maximum operating pressure does not exceed the limits in the *Technical Specifications* section.

To install the H91 Series valve:

1. Shut off power to the appliance.
2. Shut off the gas at the main manual shutoff valve.
3. Label each wire with the correct terminal designation prior to disconnection.
4. Compare the voltage on the valve with the power source voltage to ensure the correct unit is being installed. For valves with 25-volt coils, use a National Electrical Code (NEC), Class 2 transformer.  
**Note:** The transformer must be mounted to a grounded metal enclosure.
5. Ensure that the gas flows through the valve body in the direction indicated by the "IN" and "OUT" or by the arrow on the valve body. If the valve is installed with the gas flow in the opposite direction, leakage can occur.

**IMPORTANT:** Do not use a wrench on any surface other than the casting flats provided at the inlet and outlet ends of the valve body. The H91 Series may be damaged in the mounting process if a wrench is used on any other surface. Using a wrench incorrectly may void the warranty.

# BASCO Installation Instructions

6. The H91 Series valve may be mounted on a horizontal manifold with the solenoid coils pointed up (vertical) or in any position not exceeding 90° from the vertical. The valve may also be mounted on a vertical manifold in any position around its axis (see Figure 1). **Do not** install the solenoid coil upside down. Install vertically wherever possible.

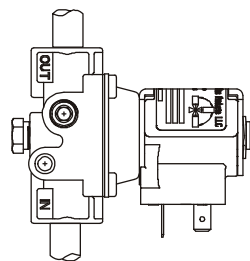
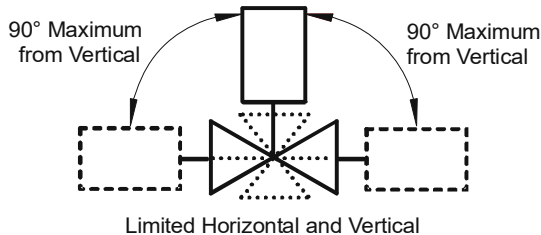

Vertical mounting may be 360° around its axis with the gas flow either up or down.

## Figure 1: H91 Series Mounting Positions

7. Installer must be a trained, experienced, flame safeguard control technician. Threads of the pipe and nipples must be smooth and free of tears and burrs. A sediment trap should also be installed in accordance with the National Fuel Gas Code NFPA 54 (see Figure 4). Mount the valve to the pipework, use a quality rated pipe tape, UL listed seal material rated for gasoline, propane, and other gases. If not available, a quality grade pipe dope, a light amount on the male threads, starting two threads away from the first engaging thread. If pipe dope lodges on the valve seat, it will prevent proper closure. Remove excess compound after mounting the valve to the pipework.
8. Thread pipe (the amount shown in Table 1) for insertion into the control. Do not thread the pipe too far. Valve distortion or malfunction may result if the pipe is inserted too deeply.

Table 1: NPT Pipe Thread Length into Valve

Pipe Size (NPT) or BSPT	Thread Pipe Amount (in.)	Maximum Depth Pipe (in)
1/2	3/4	1/2
3/4	13/16	3/4

9. For any threaded connections, threads of pipe and nipples must be smooth and free of tears and burrs. Steam clean all piping inside diameter to remove foreign substances such as cutting oil or thread chips before installing into the valve. Apply a moderate amount of good quality pipe compound (do not use Teflon tape) to pipe only, leaving two end threads bare (see Figure 2). On LP installation, use compound resistant to LP gas

CORRECT



APPLY A MODERATE AMOUNT OF PIPE COMPOUND TO PIPE ONLY (LEAVE TWO END THREADS BARE),

WRONG



CAUTION: EXCESSIVE COMPOUND MAY BLOCK DISC OFF VALVE SEAT CAUSING LEAKS.

## Figure 2 Use a Moderate Amount of Pipe Compound

10. Connect pipe to gas control inlet and outlet. Use a wrench on the square ends of the control. If a flange is used, place the wrench on the flange rather than on the control. This process should be used for both the installation and removal of the valve in a gas system. (see Figure 3)

# BASCO Installation Instructions

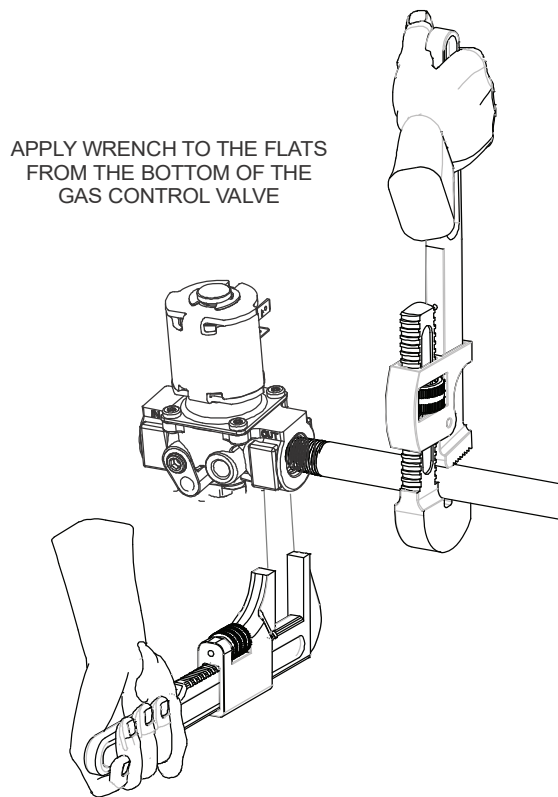

**Figure 3: Proper Use of Wrench  
on Gas Control**

**\*\*DO NOT USE THE COIL FOR LEVERAGE**



**WARNING: Risk of Explosion or Fire.**

Verify that there are no gas leaks by testing with appropriate equipment. Never use a match or lighter to test for the presence of gas. Failure to test properly can lead to an explosion or fire and may result in severe personal injury or death.

11. Check for leakage:
  - a. Shut off the gas at the main manual shutoff valve and open the pressure connection between the manual shutoff valve and the H91 Series valve.
  - b. Connect air tubing with a maximum pressure of 1-1/2 times the valve's maximum operating pressure (as indicated on the valve) to the opened pressure connection.
  - c. Paint all valve body connections with a rich soap and water solution.

If bubbles occur, this is an indication of a leak. To stop a leak, tighten joints and connections. Replace the part if the leak cannot be stopped.

If bubbles do not occur, remove the air tubing and close the pressure connection.
12. Make wiring connections. Refer to the *Wiring* section for specific wiring instructions.
13. Perform the *Checkout* section before leaving the installation.

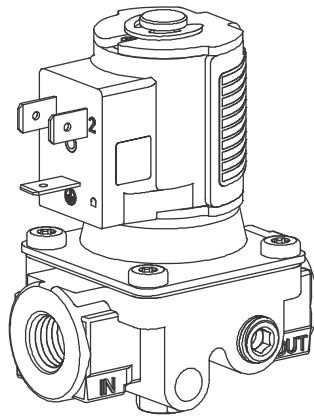

**H91A, B, C, D, E, J, K, N, S, T, V, W, X, AA, AB, AC, AD**

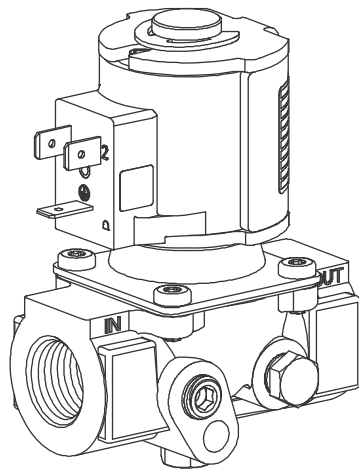

**H91L, R, AR**

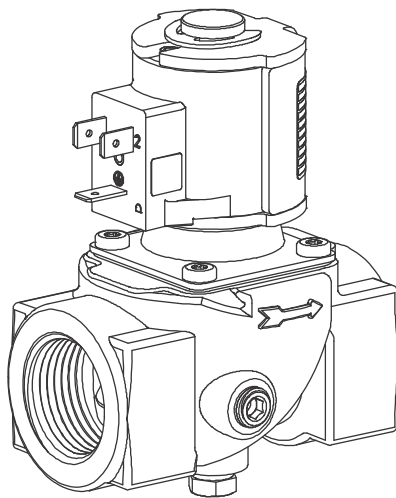

**H91M, AM**

**Figure 4: H91 Series Gas Valves**

# BASCO Installation Instructions

## Wiring



### WARNING: Risk of Shock.

Disconnect the power supply before making electrical connections to avoid electrical shock or equipment damage. Ensure that the operating voltage is identical to the information on the product identification label.

The H91 Series valve is supplied with 3-tab and 2-tab electrical connections. The tabs of the solenoid coil are male tag terminals, and electrical connections should be made using 1/4 in. (6.35 x 0.8 mm) female, fully insulated push-on terminals. The earth ground terminal is clearly labeled with the earth ground symbol (see Figure 5).

Note: Electrical connections can also be made using electrical plugs (DIN 43650 [ISO 4400]). Available from a BASCO Gas Products distributor.

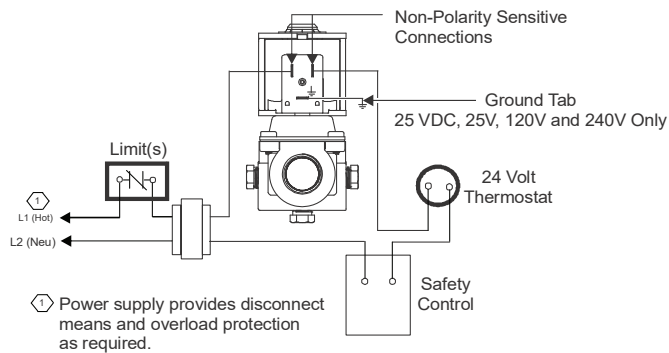

Figure 5: Electrical Connections

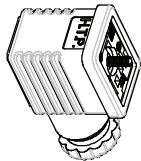

Figure 6: SVC200 Wire Connect DIN Type Connector

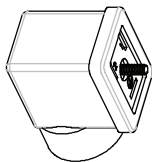

Figure 7: SVC210 Conduit 1/2 NPT DIN Type Connector

## Setup and Adjustments

### Checkout

#### IMPORTANT:

All adjustments must be made in conjunction with the gas appliance and in accordance with the appliance manufacturer's instructions. Only authorized personnel should make adjustments.



### WARNING: Risk of Explosion or Fire.

Follow this or an equivalent checkout procedure after installation. Before leaving the installation, verify that the gas valve functions properly and that the system has no gas leaks. Gas leaks can lead to an explosion or fire, and may result in severe personal injury or death.

Make sure all components are functioning properly by performing the following test.

1. Test all joints and connections for leaks with a rich soap and water solution. If leaks occur, see Step 11 in the *Installation* section.
2. Close the main manual shutoff valve and wait at least 5 minutes for unburned gas to escape from the appliance, and then reopen the shutoff valve.
3. Turn on the main electrical power switch and close the thermostat contacts. The appliance should operate in accordance with the manufacturer's specified sequence of operation.
4. Turn the thermostat to a low dial setting to open the contacts. All burner flames should be extinguished. Repeat Steps 3 and 4 in this section at least three times.
5. Return the thermostat to a normal setting before leaving the installation.

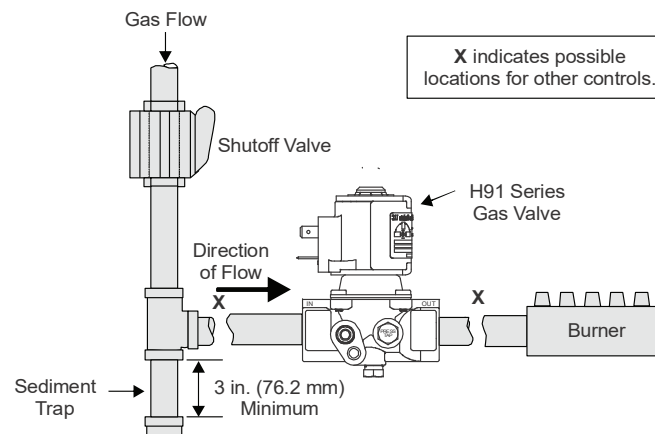

Figure 8: Typical H91 Installation

## Repairs and Replacement

**Table 1: Replacement Solenoid Coil (H91A, B, C, D, E, J, K, L, N, R, S, T, V, W, X, AA, AB, AC, AD, AR)**

Part Number	Description
RSDA95A-12	12 VDC; 2-tab 10.5 VA Coil
RSDA95A-25	25 VAC; 50/60 Hz; 3-tab 10.5 VA Coil
RSDA95A-120	120 VAC; 50/60 Hz; 3-tab 10.5 VA Coil
RSDA95A-240	240 VAC; 50/60 Hz; 3-tab 10.5 VA Coil

**Table 2: Replacement Solenoid Coil (H91H, M, AM)**

Part Number	Description
RSDA16A-25	25 VAC; 50/60 Hz; 3-tab 15 VA Coil
RSDA16A-120	120 VAC; 50/60 Hz; 3-tab 15 VA Coil
RSDA16A-240	240 VAC; 50/60 Hz; 3-tab 15 VA Coil



**CAUTION: Risk of Electric Shock.**  
Disconnect power supply before making electrical connections to avoid electric shock.



**WARNING: Risk of Explosion or Fire.**  
Shut off the gas supply at the main manual shutoff valve before installing or servicing the H91 Series. Failure to shut off the gas supply can result in the release of gas during installation or servicing, which can lead to an explosion or fire, and may result in severe personal injury or death.



**WARNING: Risk of Explosion, Fire, or Electric Shock.** Label all wires before they are disconnected when replacing or servicing the H91 Series. Wiring errors can cause improper or dangerous operation and may result in an explosion, fire, or electric shock leading to severe personal injury or death.

## Maintenance Schedule

Preventive maintenance programs are an important part of maintaining optimum and safe function of your BASO products. Commercial cooking and other heating equipment can be a heavy cycling demand on gas safety controls.

The maintenance programs should include frequent checkout of the gas controls. Review the procedure as described in the setup and adjustments and check for leakage section of the instructions.

Exposure to water, chemicals, dirt, heat and grease can all contribute to premature shut down of the gas controls.

The frequency of the maintenance must be determined by the appliance manufacturer where the controls are installed and the end user for each individual application.

Things to consider when determining a preventive maintenance program:

- Number of cycles a gas control will see annually (more than 20,000 cycles). The gas control should be checked monthly.
- Gas controls used less than 20,000 cycles should be checked before every shutdown and restart process.
- Heavy grease, high heat, wash down exposure, corrosive environment areas should be checked with a higher frequency to prevent premature shutdown from rapid deterioration.

Simply doing a scheduled maintenance program will help remove the chances of a costly unexpected shutdown.

Field repairs **must not** be made to the H91 Series valve as this will void the manufactures warranty. Never try to replace a gas control unless you are a authorized licensed gas contractor. In all cases, use an authorized licensed gas contractor for any gas control replacement. For a replacement valve or valve accessories, contact the original equipment manufacturer or the nearest BASO Gas Products distributor.

# BASCO Installation Instructions

## Technical Specifications

<b>Product</b>	H91 Model Rev. B Series BASOTROL Shutoff Gas Valve
<b>Rated Inlet Pressure</b>	0.5 psi (35 mbar [3.5 kPa])
<b>Valve Body</b>	Aluminium
<b>Permissible Ambient (Surface) Temperature</b>	-20 to 175°F (-29 to 79°C)
<b>Conduit Connection Replacement</b>	SVC200 replaces wire leads SCV210 replaces conduit 1/2 NPT connector
<b>Electrical Rating</b>	12 VDC, 10.5 VA, 0.875 A 25 VAC, 50/60 Hz, 10.5 VA, 0.42 A 120 VAC, 50/60 Hz, 10.5 VA, 0.088 A 240 VAC, 50/60 Hz, 10.5 V A, 0.044 A 25 VAC, 50/60 Hz, 15 VA, 0.595 A 120 VAC, 50/ 60 Hz, 15 VA, 0.13 A 240 VAC, 50/60 Hz, 15 VA, 0.063 A
<b>Wiring Connections</b>	1/4 in. (6.35 mm) male quick-connect terminals
<b>Inlet and Outlet Pipe Size</b>	1/8, 1/4, 3/8, 1/2, 3/4, and 1 in. NPT; 1/4, 3/8, and 1/2 in. cc; 3/8 Rp
<b>Types of Gas</b>	Natural, Liquefied Petroleum (LP), or LP gas-air mixtures
<b>Packaging</b>	Bulk pack supplied to original equipment manufacturer (individual pack optional)
<b>Bulk Pack Quantity</b>	40 or 80 (depending on the valve size)
<b>Bulk Pack Weight</b>	40 to 52 lb (18 to 24 kg)
<b>Agency Listing</b>	CSA Certificate Number 229521-1656058 except H91TB Australian Gas Association Certificate Number 4235, AGA Class 3 (H91A_, B_, C_, D_, E_, L_, and M_ only) UL Recognized File Number MH5939 (H91A_, B_, C_, D_, E_, J_, L_, R_, and W_ only) UL Listed File Number MH5939 (H91AA_, AB_, AC_, AD_, AM_, and AR_ only)
<b>Specification Standards</b>	ANSI Z21.21, CSA 6.5 AS 4629 UL Standard 429

Performance specifications are nominal and conform to acceptable industry standards. All agency certification of BASO products is performed under dry and controlled indoor environmental conditions. Use of BASO products beyond these conditions is not recommended and may void the warranty. Product must be protected if exposed to water (dripping, spraying, rain, etc.) or other harsh environments. The original equipment manufacturer and end user is responsible for the correct application of BASO products. Consult BASO Gas Products LLC for questionable applications. BASO Gas Products LLC shall not be liable for damages or product malfunctions resulting from misapplication or misuse of its products.

Refer to the H91 Series BASOTROL® Automatic Gas Valve Product Bulletin (BASO-PB-H91) for necessary information on operating and performance specifications for this product.

