

Replacement Parts List

Economite Model DS45B Conversion Burners

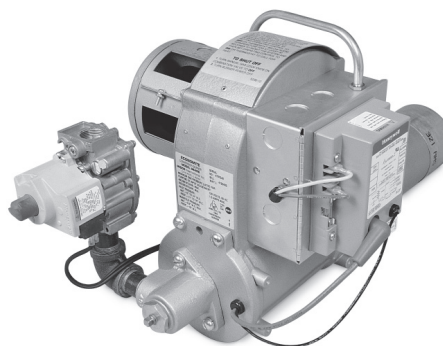

DS45B is Obsolete
as of January 1, 2022

*Installation and Service Manual - 8470-72
Date Code -*

- First construction started May 30, 1993 (date code 2293).
- Features a Honeywell DSI Electronic Control Board.
- Supersedes Model DS45. Model DS45B was assigned to alleviate possible confusion replacing gas valves.



Midco®
INTERNATIONAL

Midco® International Inc.
4140 West Victoria Street
Chicago, Illinois 60646
toll free 866.705.0514
tel 773.604.8700
fax 866.580.8700
web www.midcointernational.com
e-mail sales@midcointernational.com

AVOID ERROR IN PARTS SELECTION. When ordering use complete MIDCO Part Number and Description. Furnish Burner Model Number, Bill of Material Number and Serial Number (if available) from the specification plate found on the product.

IMPORTANT: Availability of parts as well as specifications are subject to change without notice. Please consult factory for item availability.



As an ISO 9001:2008 certified company, we proudly design, manufacture and assemble our products in Chicago, Illinois, USA.

Quality Designed for Proven Performance

425
8472 58
Printed in USA

Exploded View DS45B

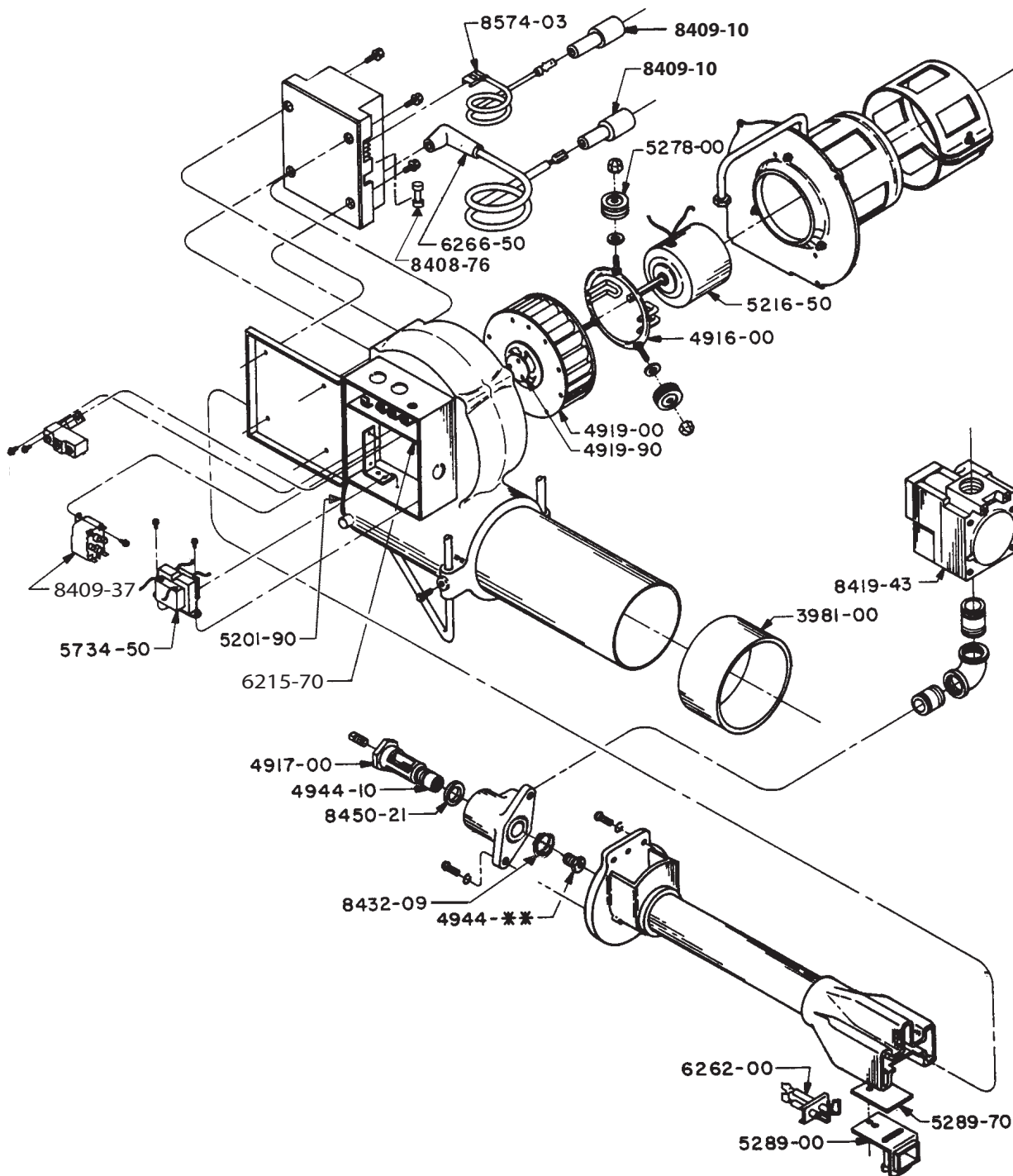

Component layout may not be as shown
** Refer to listing for proper application.

Parts List DS45B

Item	Part #	Description	Item	Part #	Description
3981-00		4" Dia. Stainless Nozzle Sleeve	6215-70		Terminal Strip only
4916-00		Motor Mounting Ring less Rubber Mounts and Nuts	6262-00		Electrode Assembly (order Mounting Bracket and Gasket separately)
4917-00		Main Orifice Holder	6266-50		Hi-Voltage Cable (order Silicone Boot for Spark Electrode separately)
4919-00		Blower Wheel complete with Centrifugal Actuator and Disc	8409-37		Motor Switching Relay-24V
4919-90		Centrifugal Actuator Disc	8408-76		3-Amp type 3AG Glass Fuse-1/4" Dia. X 1 1/4" LG
4944-01		Main Spud 11/32 Drill (.343) minimum capacity-NATURAL	8409-10		Silicone Boot - Orange
4944-02		Main Spud 25/64 Drill (.390) maximum capacity-NATURAL	8419-43 ¹		3/4" 3-Function Redundant Main Valve with Regulator (M-H VR8305M4009)
4944-10		Main Spud Extension(s)	8432-09		O-Ring Seal
5201-90		400-Series Rubber Seal Strip	8450-21		Orifice Holder Sealing Gasket
5216-50		Motor less Mounting Ring and Rubber Mounts 120/1/60 (Universal Electric JB2P048N#; Fasco 7163-7511)	8470-72 *		Installation and Service Manual
5278-00		3 Rubber Mounts and Nuts	8574-03		Sensor Wire (order Silicone Boot for Flame Sensor separately)
5289-00		Electrode Mounting Bracket	2032000 *		DS45B PROPANE Kit
5289-70		Electrode Mounting Bracket Gasket	2020100 *		4" Dia. Mounting Flange
5292-00 *		DS45B Valve Wire Assembly	2020400 *		4" Long Accessory Blast Tube Extension
5734-50		Transformer 115/1/50-60 Primary, 24V-30VA Secondary (Prod. Unlimited 4000-01M07J232, 4000-01M07K232; Basler BE121630GDD, BE121630GAA)	2020500 *		8" Long Accessory Blast Tube Extension

* Not illustrated

- ¹.  **WARNING:** Explosion hazard. Can cause serious injury or death. An electronic device can malfunction if it gets wet. Never try to use a device that has been wet-replace it.

DS45B Parts List



Midco[®]
INTERNATIONAL

As an ISO 9001:2008 certified company, we proudly design, manufacture and assemble our products in Chicago, Illinois, USA.

Midco[®] International Inc. - 4140 West Victoria Street - Chicago, Illinois 60646 - toll free: 866 705 0514
tel: 773.604.8700 - fax: 866.580.8700 - web: www.midcointernational.com - e-mail: sales@midcointernational.com