

Replacement Parts

List Economite Models F400-13

F400-23

F400-33

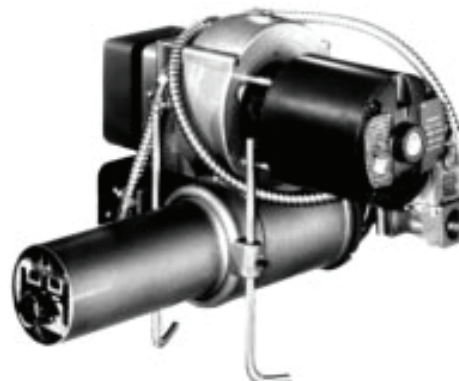

*For manufacturing dates and manual availability,
refer to historical data below and on page 2.*

This burner has been manufactured since 1961 and has been relatively unchanged except for various pilot styles described on page 4. Pilot styles can be determined by the double digit suffix following "Model F400" on the rating plate.

- Serial number discontinued April 1969 with 94,000
- Date coding started April 1969 with 1769 (17th week, 1969)
- Pressure tap moved from "B" cock assembly to pilot solenoid February 26, 1986 (date code 986).
- Main Burner Casting with welded side baffles superseded by Main Burner Casting with cast-on side baffles February, 1991 (Date Code 0791).
- Maxitrol phased out their RV10 and RV60 Regulators February and March 1992 and replaced them with Models RV12 and RV61. Refer to notes 4 and 5, page 2.
- Honeywell R4795A Flames Safeguards superseded by Honeywell RM7895 Flame Safeguards November, 1993.
- Construction required dual Main Valves (UL 795 requirement), April 1, 1994 (Date Code 1394).

Manuals

F400-13 No inclusive bulletin is available for this limited edition burner. Refer to EC49 F400/F800-33 Installation and Service Manual (any edition 767 through 1179) for installation and general data.

F400-23 NO BULLETINS available for this limited edition burner.

F400-33 Installation and Service Manual EC49 (8448-17) for 400-33, F400-33, 800-33 and F800-33. Date coded 767 through 1179. Installation and Service Manual EC110 (8449-84). First issue date code 381.

IMPORTANT: Availability of parts as well as specifications are subject to change without notice.
Please consult factory for item availability.



Midco®
INTERNATIONAL

Midco® International Inc.
4140 West Victoria Street
Chicago, Illinois 60646
toll free 866.705.0514
tel 773.604.8700
fax 773.604.4070
web www.midcointernational.com
e-mail sales@midcointernational.com

AVOID ERROR IN PARTS SELECTION. When ordering use complete MIDCO Part Number and Description. Furnish Burner Model Number, Bill of Material Number and Serial Number (if available) from the specification plate found on the product.

IMPORTANT: Availability of parts as well as specifications are subject to change without notice.
Please consult factory for item availability.



Exploded View - Economite F400-33

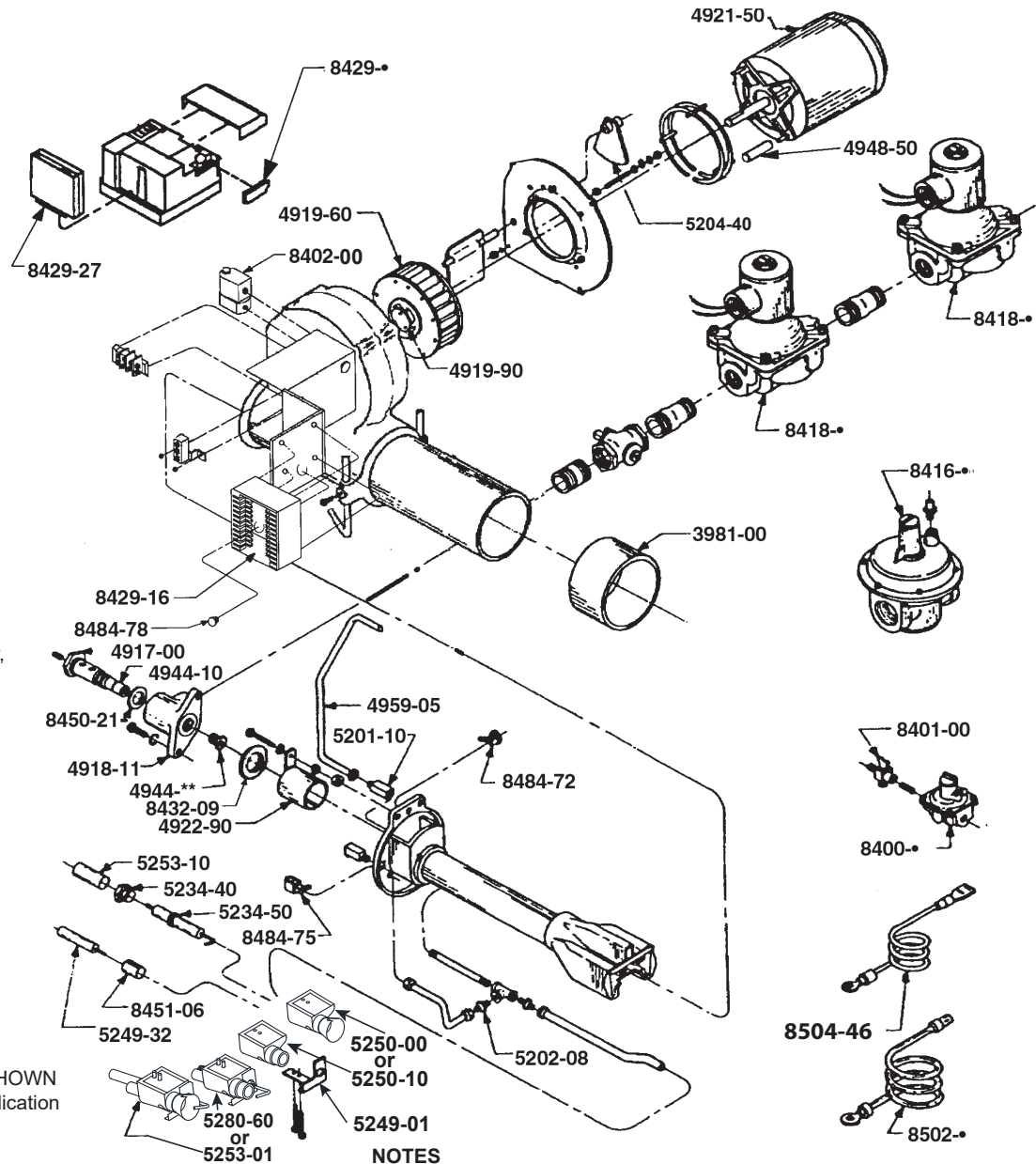

AVOID ERROR IN PARTS SELECTION. When ordering use complete MIDCO Part Number and Description. Furnish burner model number, bill of material number and date code (if available) from rating plate.

LAYOUT MAY NOT BE AS SHOWN
Refer to listing for proper application

NOTES

1. Some applications, usually O.E.M. require the use of more than one extension. Determine the exact number in your ECONOMITE before ordering.
2. 5" and 15" Blower Housing and Blast Tube Assemblies are NOT available. A 5" assembly can be fabricated by hack sawing 4" off of a 9" assembly. A 15" assembly can be made by assembling a 9" assembly with 2020500 (8" long Accessory Blast Tube Extension).
3. Maxitrol and General Controls Pilot Regulators have been used interchangeably. For exact replacement, determine the model used in your ECONOMITE before ordering. If inlet pressure exceeds 1/2 PSI or if regulating PROPANE, select 8400-00 (Maxitrol RV12LT) as the RV12LT regulates to 1 PSI and responds better to PROPANE regulation.
4. Burners have been assembled with valves and regulators built by various manufacturers (i.e. General Controls, Maxitrol, etc.). MIDCO will supply whatever brand is currently in stock, depending on price and availability. Valve or regulator body length may vary and some replacement problems may occur. 3/4" NPT and 1" NPT Main Regulators have been used interchangeably, as have 3/4" NPT and 1" NPT Main Automatic Valves. Determine the size used in your ECONOMITE when ordering. **BE CERTAIN OF VALVE SIZE.** Many early burners were sized for mixed or manufactured gases, which require larger piping. Effective June 1978, gas pipe trains were reduced one pipe size, except for one special burner. **Note: MIDCO stocks only complete valves. If magnetic operators or power heads are desired, or if exact replacement of any part is desired, they should be obtained from local distributors.**
5. When replacing Fluid Power Valves, obtain pipe size, exact valve number and brand from valve rating plate, as well as the bill of material number from the ECONOMITE rating plate. Contact MIDCO for price and availability, if not listed. Construction required dual main automatic valves April 1, 1994 (Date Code 1394). Determine the valve size(s) before ordering.
6. Contact MIDCO for availability of early EC manuals.
7. **⚠ WARNING: Explosion hazard. Can cause serious injury or death. This device can malfunction if it gets wet. Never try to use a device that has been wet, replace it.**
8. DECODING CENTURY MOTOR NUMBERS. Single digit prefix denotes manufacturer's location. Double digit suffix denotes manufacturer's mechanical code.
9. Honeywell R4795A Flame Safeguards were phased out of production November, 1993. Replaced by Honeywell RM7895 Flame Safeguards. Determine which version is required before ordering.
10. Honeywell Spark Generator was introduced in July, 1994. As standard construction.

Parts List - Economite F400-33

Part #	Description	Part #	Description
3981-00	4" Diameter Stainless Sleeve	8416-33 ⁴	1" NPT Main Gas Pressure Regulator - NATURAL (Maxitrol RV60, RV61)
4917-00	Main Orifice Holder	8418-01 ⁴	3/4" NPT Main Automatic Valve 120/1/60
4918-11	Orifice Elbow (1" NPT)	8418-03 ⁴	1" NPT Main Automatic Valve 120/1/60
4919-60	Blower Wheel with Centrifugal Actuator and Disc	8418-31 * ⁵	Main On-Off Motorized Valve Actuator without Proof of Closure Switch (Honeywell V4055A)
4919-90	Centrifugal Actuator Disc	8418-32 * ⁵	1" Main Motorized Valve Body without Proof of Closure Switch (Honeywell V5055A)
4921-50 ⁸	1/6 HP Motor 120/230/50/60 (Service Bulletin 8470-39 is included.)	8429-16 ^{7,9}	Q7800B Subbase
4922-90	Primary Air Shutter Kit	8429-22 ^{7,9}	30-Second Purge Timing Card (Honeywell ST7800A1039)
4944-02	Main Spud 25/64" Drill (.390) minimum capacity - NATURAL - drill 7/16" (.437) for 400/540 MBH range and omit for 540/700 range	8429-25 ^{7,9}	90-Second Purge Timing Card (Honeywell ST7800A1062)
4944-03	Main Spud #21 Drill (.159) minimum capacity - PROPANE - drill for desired capacity per manual	8429-27 ^{7,9}	Rectification Amplifier (Honeywell R7847A1033)
4944-10	Main Spud Extension	8432-09	"O" Ring Orifice Elbow Seal
4948-50	Motor Spacer (4 required)	8433-10	Pilot Spud (.032) - NATURAL (2-15M1-032, Y90AA-5232)
4959-05	External Pilot Air Tube Kit	8447-11 ¹⁰	Ignition Transformer 120/1/60 primary, 6000 volts secondary (Webster 612-6A020, 612-6A044; France 3RABVR-19; Jefferson #638-181)
5201-10	1/2" sq. Pass Thru for 5/16" Tube Fitting (air line)	8447-22 ¹⁰	Honeywell Spark Generator (MH Q652B)
5202-08	Pilot Spud #55 (.052) Drill [was #54 (.055)] - NATURAL and PROPANE	8448-17 * ⁶	EC49 Installation and Service Manual
5204-40	Quadrant - Air Shutter Adjustment	8449-84 * ⁶	EC110 Installation and Service Manual
5234-40	Flamerod Gland Nut	8450-21	Orifice Holder Sealing Gasket
5234-50	Flamerod Assembly	8451-06	Spark Rod Insulator Sleeve
5249-01	Pilot Air Baffle	8484-72	Heyco Strain Relief (SR-4K-1) - Flamerod Wire
5249-32	Spark Rod Assembly	8484-75	Heyco Strain Relief (SR-11-2) - Spark Rod Wire
5250-00	Pilot Body with Cone Tip, less Insulators, Rods, Temflex and Baffle	8484-78	Heyco Snap Bushing (B-875-750) - Control Box
5250-10	Pilot Body with Ring Tip, less Insulators, Rods, Temflex and Baffle	8502-05	Spark Cable - 15" Burner Tube
5253-01	Pilot Assembly with Cone Tip, Insulators, Rods, Temflex and Baffle	8502-06	Spark Cable - 5" through 9" Burner Tube
5253-10	PVC Tubing - 7/16" I.D. x 2" long	8504-46	Flame Rod Wire Assembly 19"
5280-60	Pilot Assembly with Ring Tip, Insulators, Rods, Temflex and Baffle	2020100 *	4" Mounting Flange
8400-00 ³	1/8" NPT Pilot Regulator - 1 PSI maximum inlet (Maxitrol RV10, RV12, RV12LT)	2020400 *	4" long Accessory Blast Tube Extension (Service Bulletin 8448-94 is included)
8400-05 ³	1/8" NPT Pilot Regulator - 1/2 PSI maximum inlet (General Controls V300)	2020500 *	8" long Accessory Blast Tube Extension (Service Bulletin 8448-94 is included)
8401-00	1/8" NPT Pilot "B" Cock	2020300 *	Kit to convert NATURAL burner to PROPANE; includes minimum spud to be drilled per manual, Main Regulator Spring, Instructions, etc.
8402-00	1/8" NPT Pilot Solenoid 120/1/60		
8402-06 ⁵ *	1-1/4 Solenoid Valve 120/1/60		
8416-01 ⁴	3/4" NPT Main Gas Pressure Regulator - NATURAL (Maxitrol RV53)		
8416-02 ⁴	1-1/4" NPT Main Gas Pressure Regulator - NATURAL (Maxitrol RV60, RV61)		
			No Longer Available
		8429-19 ^{7,9}	RM7895A Controller - Call Factory

* NOT SHOWN

Pilots - Economite F400-M3, 13, 23 & 33

PILOTS

The current MIDCO -33 Spark Ignited Pilot has evolved through a number of designs since MIDCO built its first F400 Series burner with spark ignition and flamerod electronic safety. Listed below are brief descriptions of each design, approximate production dates and parts availability. Many Burners have been converted to the current production -33 Pilot.

IMPORTANT: Frequently, the serviceman fails to adequately remark the rating plate with the new pilot designation when a burner is converted. For example, when a Model F400-13 burner is converted to a -33 pilot, the rating plate should be modified to read F400-33. It is critical that you confirm that the rating plate reflects the actual pilot design before ordering parts.

Production dates overlap considerably, as some O.E.M. accounts chose not to change pilot models until their next U.L. recertification review.

First Production: October 1962
Discontinued: Date unknown

Used primarily on burners supplied to Mammoth Industries

Available Parts:
8433-10 Pilot Spud .032 NATURAL

TYPE M3 PILOT

Identifiable Feature:
2 Flat baffles

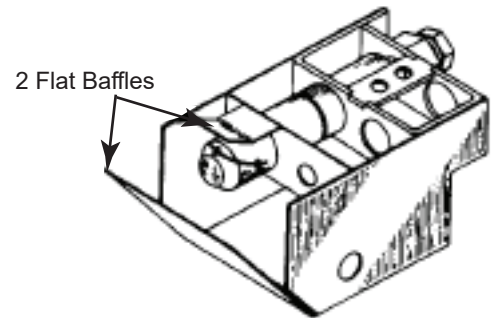

First Production: April 1962
Discontinued: January 1970

Available Parts:
8433-10 Pilot Spud .032 NATURAL

TYPE 13 PILOT

Identifiable Feature:
Formed baffle

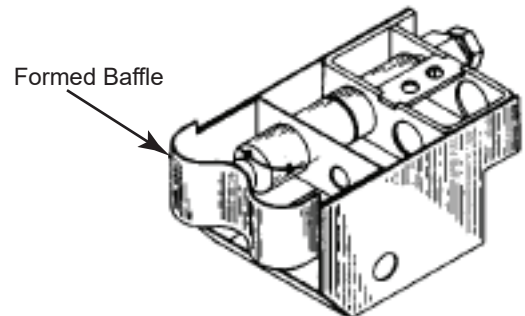

First Production: March 1965
Discontinued: October 1966

NO PARTS AVAILABLE FOR THIS PILOT

TYPE 23 PILOT

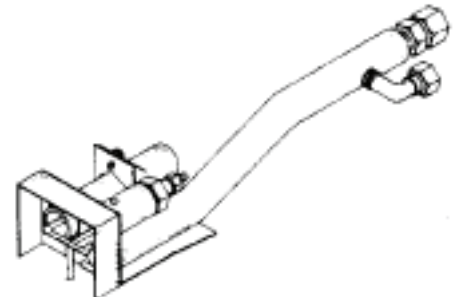

First Production: October 1966

ALL PARTS ARE AVAILABLE FOR THIS PILOT REFER TO LISTING

TYPE 33 PILOT

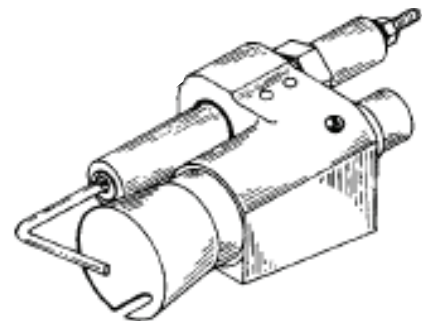

Midco®
INTERNATIONAL

Midco® International Inc. - 4140 West Victoria Street - Chicago, Illinois 60646 - toll free: 866 705 0514
tel: 773.604.8700 - fax: 866.580.8700 - web: www.midcointernational.com - e-mail: sales@midcointernational.com



525b
8472 02
Printed in USA