

# Installation and Service Instructions

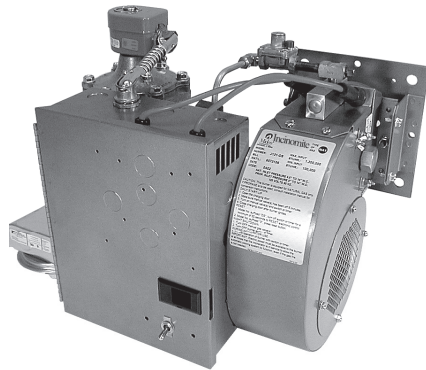

## Incinomite Model J121-DS Gas Burner

The INCINOMITE Model J121-DS gas burner features direct main flame spark ignition and solid state electronic flame verification.

- In the United States, installation must conform with local codes or in the absence of local codes, with the National Fuel Gas Code, ANSI Z223.1-latest edition available from American National Standard Institute. Further reference should be made to the recommendation of your fuel supplier.
- In Canada, installation must conform with local codes or in the absence of local codes, with Installation Codes for Gas Burning Appliances and Equipment, CGA Standard CAN/CGA 1-B-149.1 or 2.
- **⚠ WARNING:** Additions, changes, conversions and service must be performed by an authorized Midco representative, service agency or the fuel supplier. Use only MIDCO specified and approved parts.
- **INSTALLER:** Inform and demonstrate to the user the correct operation and maintenance of the gas utilization equipment. Inform the user of the hazards of storing flammable liquids and vapors in the vicinity of this gas utilization equipment and remove such hazards. Affix this manual and associated literature to the burner.  
**CODE COMPLIANCE IS THE SOLE RESPONSIBILITY OF THE INSTALLER.**
- **USER:** Retain this manual for future reference. If other than routine service or maintenance as described in this manual and associated literature is required, contact a qualified service agency. **DO NOT ATTEMPT REPAIRS.** An inadvertent service error could result in a dangerous condition.

**AVOID ERROR IN PARTS SELECTION.** When ordering use complete MIDCO Part Number and Description. Furnish Burner Model Number, Bill of Material Number and Serial Number (if available) from the specification plate found on the product.

**IMPORTANT:** Availability of parts as well as specifications are subject to change without notice. Please consult factory for item availability.



**Midco**<sup>®</sup>  
INTERNATIONAL

Midco<sup>®</sup> International Inc.  
4140 West Victoria Street  
Chicago, Illinois 60646  
toll free 866.705.0514  
tel 773.604.8700  
fax 866.580.8700  
web [www.midcointernational.com](http://www.midcointernational.com)  
e-mail [sales@midcointernational.com](mailto:sales@midcointernational.com)

**SAFETY INFORMATION TERMS:** The following terms are used to identify hazards, safety precaution of special notations and have standard meanings throughout this manual. They are printed in all capital letters using a bold type face as shown below, and preceded by the exclamation mark symbol. When you see the safety alert symbol and one of the safety information terms as shown below, be aware of the hazard potential.



**DANGER:** Identifies the most serious hazards which will result in severe personal injury or death.  
**WARNING:** Signifies a hazard that could result in personal injury or death.  
**CAUTION:** Identifies unsafe practices which would result in minor personal injury or product and property damage.

**⚠ WARNING: If the information in these instructions is not followed exactly, a fire or explosion may result, causing property damage, personal injury or death.**

Do not store or use gasoline or other flammable vapors and liquids in the vicinity of this or any other appliance.

### WHAT TO DO IF YOU SMELL GAS:

- Do not try to light any appliance.
- Do not touch any electrical switch; do not use any phone in your building.
- Immediately phone your gas supplier from another building. Follow the gas supplier's instructions. If you cannot reach your gas supplier call the fire department.

Installation and service must be performed by a qualified installer, service agency or the gas supplier.

**BURNER MODEL:** \_\_\_\_\_

**BILL OF MATERIAL NUMBER:** \_\_\_\_\_

**SERIAL NUMBER #:** \_\_\_\_\_

**WIRING DIAGRAM:** \_\_\_\_\_

### FOR SERVICE CONTACT

**Name:** \_\_\_\_\_

**Address:** \_\_\_\_\_  
\_\_\_\_\_

**Phone:** \_\_\_\_\_

**Date of Installation:** \_\_\_\_\_



As an ISO 9001:2008 certified company, we proudly design, manufacture and assemble our products in Chicago, Illinois, USA.

Quality Designed for Proven Performance



1024  
8471 15  
Printed in USA

# Specifications

## Specifications <sup>1</sup>

|  |                         |
|--|-------------------------|
| <b>BURNER AIR DELIVERY</b>   |                         |
| Approximate Air Delivery at Zero Draft .....   | 180 SCFM <sup>2</sup>   |
| <b>MINIMUM GAS PRESSURE LISTED FOR PURPOSE OF INPUT ADJUSTMENT</b>   |                         |
| (Take Pressure at Inlet Tap of Main Automatic Valve)   |                         |
| NATURAL .....  | 5.5" W.C.               |
| PROPANE .....  | 8.0" W.C.               |
| <b>BURNER FIRING RATE (NATURAL OR PROPANE) <sup>3</sup></b>  |                         |
| MINIMUM .....  | 100 MBH <sup>4</sup>    |
| MAXIMUM (With Combustion Air From Burner Only).  |                         |
| 20% Excess Air .....   | 900 MBH                 |
| 0% Excess Air (stoichiometric) .....   | 1080 MBH                |
| MAXIMUM (With Combustion Air From Burner Blower and Additional Air Available in Combustion Chamber.)   |                         |
| NATURAL Gas 5.5" W.C. or PROPANE Gas at 11.0" W.C.   |                         |
| Gas Pressure at Main Automatic Valve .....   | 1,200 MBH               |
| ELECTRICAL SUPPLY .....  | 120/1/60;4.5 amps       |
| BURNER ON-OFF CONTROL .....  | Toggle Switch.          |
| FLAME SAFETY .....   | Electronic Flame Safety |
| with spark ignited ignitor (pilot) and 100% shut-off.  |                         |
| ADJUSTABLE FIRING ANGLE .....  | Mounting Flange         |
| adjustable for horizontal or 10° down firing.  |                         |
| NOTE: Burner components are UL recognized, CGA listed, CSA certified and/or AGA design certified, mounted and wired. The complete burner is fire tested. |                         |

1. Standard burners are shipped as NATURAL gas models. A kit is available for field conversion to PROPANE gas.
2. SCFM = Standard Cubic Feet/Minute.
3. NOTE: Firing rate with combustion air from burner blower only is based on using standard air at sea level with zero draft over-fire. De-rate burner for altitudes over 2,000 feet by 4% for each 1000 feet of additional elevation.
4. 100 MBH = 100,000 BTU/Hr.

## Part 1 - Installation

### I Primary Chamber Fuel Input

- **No. 1 Waste:** Primarily dry material such as paper, rags and wood. Burner normally required only for light-off.
  - **No. 2 Waste:** Consisting of approximately equal portions, by weight of No. 1 and No. 3 waste; 70 lbs. per 100 MBH.
  - **No. 3 Waste:** Wet material such as garbage; 25 lbs. per 100 MBH.
  - **No. 4 Waste:** Organic materials such as small carcasses and waste from hospital operating rooms or pathological laboratories; 13 lbs. per 100 MBH.
- NOTE:** The burner input required for the secondary chamber must be determined from the heat required to maintain the discharge temperature of the flue products as specified by the EPA for the type of waste involved and the location of the incinerator.

### II Indoor Ventilation

Make sure that the incinerator room has sufficient ventilation to provide the necessary combustion air for the burner fuel, the waste material and any other appliance that would draw its air from the same enclosed area.

**⚠ WARNING:** Under no condition should the access to outside air be so restricted that the maximum possible use of combustion air is inhibited. Pay particular attention to exhaust fans that could draw air from the area and create a negative pressure in the room

Install the INCINOMITE burner(s) in location(s) specified by the incinerator manufacturer. It should be positioned approximately level with the top of the highest normal load and fire with or across the draft flow.

- If the incinerator is designed only for No. 4 waste, the level can be lowered to bring the flame to play directly on the smaller loads characteristic of this type of operation. The opening through which the burner fires should be of a diameter only large enough to accommodate the Blast Tube (4 1/4" diameter x 3" minimum long.) Do not allow the Blast Tube to protrude into the incineration chamber. If necessary, build an extension outside of the incinerator wall to increase wall depth.
- To change the Mounting Flange to its alternate position, horizontal or 10° down firing, remove the four (4) screws that attach it to the burner, rotate the flange 180° and reinstall the screws.
- Before mounting the burner, check that the Blast Tube and Blower Housing are clear of foreign material and that the Main Gas Port and Nozzle Support is clean and undamaged.
- If the incinerator is located outdoors, the burner and all of its components, except the Main Manual Shut-Off Valve, must be protected from weather. The MIDCO Accessory Weatherhood will provide such protection.

**⚠ CAUTION:** If the incinerator is of the down draft design, make sure that a direct draft vent opening of approximately 10 square inches has been put through the top of the drop section(s) to provide for the venting of any gas leakage. See Figure 1.

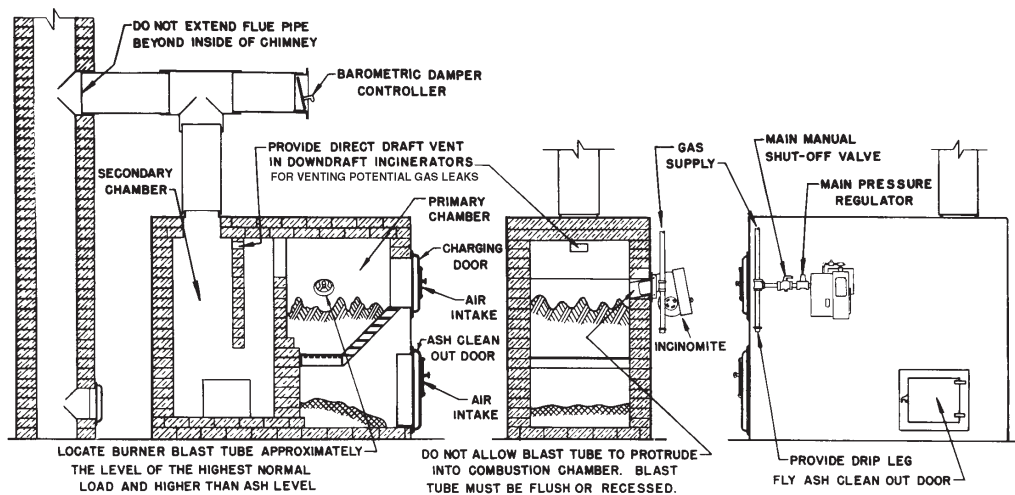

Figure 1 Typical Installation

The size and type of material used for the vent connector and chimney must conform to the recommendations of the incinerator manufacturer, as well as local and national codes. This is especially true where high flue gas temperatures are encountered.

- When natural draft is used and the chimney height is over 25 feet, a barometric damper of the same size as the vent connector should be installed. If the chimney is high enough to make it difficult for the barometric to maintain a maximum incineration chamber over-fire draft, 0 to minus 0.5" W.C., a **fixed** damper should be installed in the vent connector between the barometric and chimney to restrict the chimney draft to a point within the controlling capacity of the barometric. After final setting, the damper should be permanently fastened into position per ANSI Z223.1-latest edition "National Fuel Gas Code", or latest edition available from American National Standards Institute to prevent tampering.

## IV Chimney, Vent Connector\* and Draft Control

\*Formerly referred to as **FLUE PIPE**

# Part 1 Installation

V

## Piping

The supply piping to the burner should branch off from the main line as close to the source as possible (NATURAL gas meter or PROPANE tank regulator). When branching off from an existing gas line, do not tap off the bottom of a horizontal section. Use new black pipe and malleable fittings free from cutting and threading burrs or defects.

- Use pipe joint compound resistant to liquid petroleum gases when using either NATURAL or PROPANE gas. Piping must comply with the local and national codes. If the burner piping must be rearranged because of space limitations, be sure to carry out the general configuration shown in Figure 3.

- A suitable Main Gas Pressure Regulator should be installed as shown in Figure 1. Choose a regulator(s) to adjust the available gas pressure to the pressure shown in SPECIFICATIONS, page 2.

**CAUTION:** The regulated gas pressures must not exceed 14" W.C. or Main Automatic Gas Valve and Ignitor Regulator will be damaged. If excessive gas pressure is prevalent, the regulator must be a tight shut-off type to prevent high pressures from developing during stand-by.

- For full input, refer to SPECIFICATIONS, page 2, for minimum gas pressure required. For reduced capacities, refer to Firing Rate Curves, Table 2.

**CAUTION:** If gas supply pressure is below its specified range during adjustment, an over-fire condition could result when pressure returns to normal, particularly if the regulator adjustment screw is bottomed out. ALWAYS confirm that at least the minimum rated pressure is being supplied during regulator adjustments, and NEVER BOTTOM OUT regulator screw.

- When selecting the burner supply piping size per Table 1, the permissible pressure drop must be based on the pressure available at the inlet to the supply pipe branch line when all other gas equipment fed by the same source (NATURAL gas meter or PROPANE tank regulator) is firing at full rate. Also take into account any other INCINOMITE burners to be attached to the same branch line.

- When pressure testing the supply piping, the burner valve train must be protected. If the test pressure is 0.5 PSIG or less, closing the Main Manual Shut-Off Valve will suffice.

**CAUTION:** If the test pressure is over 0.5 PSIG, the test must be made without any burner components connected, including Main Manual Shut-Off Valves.

**WARNING: EXPLOSION HAZARD. DO NOT USE OXYGEN FOR PRESSURE TESTING. AN EXPLOSION COULD OCCUR DURING INITIAL START-UP.**

| NPT<br>PIPE<br>SIZE | TYPE<br>OF<br>GAS | APPROXIMATE CAPACITY-MBH<br>LENGTH OF PIPE / FEET |     |     |     |     |
|---------------------|-------------------|---|-----|-----|-----|-----|
|                     |                   | 10  | 20  | 40  | 60  | 100 |
| 3/4"                | Natural           | 275   | 200 | 130 | 100 | --- |
|                     | Propane           | 450   | 300 | 200 | 165 | 125 |
| 1"                  | Natural           | 520   | 350 | 245 | 195 | 150 |
|                     | Propane           | 800   | 550 | 385 | 300 | 235 |
| 1 1/4"              | Natural           | 800   | 730 | 500 | 400 | 300 |
|                     | Propane           | ---   | 800 | 790 | 630 | 480 |
| 1 1/2"              | Natural           | ---   | 800 | 760 | 610 | 460 |
|                     | Propane           | ---   | --- | 800 | 800 | 725 |
| 2"                  | Natural           | ---   | --- | 800 | 800 | 800 |
|                     | Propane           | ---   | --- | --- | --- | 800 |

*Capacities shown are for total pressure drop of 0.3" W.C. For higher permissible pressure drops consult your fuel supplier.*  
**Source:** Gas Engineers Handbook-1974  
 Industrial Press Inc. NY, NY

Table 1 Schedule 40 Pipe Capacities in MBH

VI

## Electrical

Installation wiring to the burner must conform to local codes, or, in their absence in the United States the National Electric Code ANSI/NFPA No. 70- latest edition; in Canada, to CSA standard C22.1, "Canadian Electrical Code Part 1."

- Use copper wires and provide disconnect and fuse protection for each INCINOMITE installation. Refer to SPECIFICATIONS, page 2, for ampacity. Confirm that the polarity is correct—hot wire to strip terminal L1, neutral L2 and that the neutral line is not subject to induced low voltage (check L2 to ground) from other equipment as that can affect the electronic control, causing it to malfunction.

- The frame of the burner should be well grounded. A terminal is provided in the control box for positive grounding.

**CAUTION:** In order for the automatic cooling system to function, power must be maintained to burner strip terminal L1. Do not install any safety or on-off controls in the circuit between the fused disconnect switch and strip terminal L1. Optional remote control devices should be connected in place of, or in addition to, the switch or timer as indicated in Figure 2A, 2B, 2C, or 2D Wiring Diagram.

Burners are suitable for use with NATURAL or PROPANE gas only.

- If a standard NATURAL gas model is to be used with PROPANE gas, a conversion kit is available, which contains a PROPANE Main Gas Port, a PROPANE Ignitor Tee Orifice Fitting and a PROPANE label and conversion instructions.

- As shipped, the Air Shutter is in the full open position and the Main Gas Input Adjuster 5 to 6 turns from full closed. Ignitor regulator is factory set for recommended outlet pressure of 3.5" W.C. suitable for most applications.

1. Check the burner piping and valves for gas leaks by applying a weak liquid soap solution to unions and joints with the gas supply on. Leakage will be indicated by the appearance of soap bubbles. Locate and correct all gas leaks before proceeding.

**⚠ WARNING: DO NOT USE OPEN FLAME.**

2. Confirm that the main gas Input Adjuster is 5 to 6 turns from full closed and that the Blower Air Shutter is fully open.

3. Close the Main Manual Shut-Off Valve.

4. Purging the air from the gas supply line at this step will expedite the first light-off.

**⚠ CAUTION: Purge outside the building. Do not purge into the incineration chamber.**

5. Turn on the Fused Disconnect, Burner Switch or Timer. Let motor run long enough to accomplish four air changes. Note that motor will continue to run after Electronic Control lockout occurs.

6. Open the incinerator or charging door. Making sure any **Door Open** interlock is temporarily bypassed.

7. Turn off the Burner Switch or Timer for at least 30 seconds to **reset** Electronic Control (see Section XIII ELECTRONIC CONTROL SYSTEM). Open the Main Manual Shut-Off Valve.

8. Turn on the Burner Switch or Timer. Burner Ignitor and main flame should light during the 6 second trial for ignition after the motor reaches operating speed. If the Ignitor and Main Flame fails to light during the 6 second trial for ignition, it is probably due to air in ignitor gas line. Repeat from step 7. Then, if necessary, refer to the Trouble Chart to isolate the problem.

**⚠ WARNING: Repeated unsuccessful attempts to light will result in accumulated gases in incineration chamber. To prevent these gases from reaching an explosive level, periodically purge the incineration chamber as described in Step 5.**

9. Observe the ignitor flame. If it is weak, screw in the Ignitor regulator adjustment to increase the pressure. If it is excessively rich and large or floating from the ignitor tip, back off the regulator adjustment to reduce the pressure. Set the ignitor to a stable blue flame which burns firmly within the ignitor tip. Check flame current with a micro-ammeter and adjust Ignitor Regulator slowly for highest steady 2 or more microamps.

**⚠ CAUTION: When adjusting the regulator, take note of the supply pressure. If gas supply pressure is below its specified range during adjustment, an over-fire condition could result when pressure returns to normal, particularly if the regulator adjustment screw is BOTTOMED OUT. ALWAYS confirm that at least the minimum rated pressure is being supplied to the ignitor during regulator adjustments, and NEVER BOTTOM OUT regulator screw. Operate air shutter throughout range to confirm Ignitor stability. Try several relights. Refer to Figure 4.**

10. Remove the input adjuster cap (see Figure 3) and, with the Ignitor and Main Flame on, turn the Main Gas Input Adjusting Screw (see Figure 4) until the desired input rating is reached (refer to Table 2). Turning of adjustment screw counterclockwise increases gas flow; clockwise reduces flow. If Main Flame gas pressure requires adjustment, refer to SECTION V PIPING SUPPLY.

11. Reset the Blower Air Shutter to match the intended input, i.e.; full open for maximum, closed for minimum or partially open for midrange. The Blower Air Shutter is factory set wide open. Adjust as necessary when, with combustion air available in the incineration chamber, it is desirable to increase the flame length, or to restrict the amount of excess air discharged into the incineration chamber when the burner input is below 450 MBH.

12. The actual NATURAL gas firing rate in BTU per hour can be determined by timing the gas meter. Accurately time the meter test dial for one revolution, convert to hourly cubic feet and multiply by the BTU per cubic foot value of your gas per formula:

$$\frac{3600 \times \text{Test dial Size} \times \text{BTU Value}}{\text{No. of Seconds for One Rev. Test Dial}} = \text{BTU / Hr.}$$

Then divide by 1,000 for MBH value.

EXAMPLE:  $\frac{3600 \times 1 \times 1000^*}{20} = 180,000 \text{ BTU / Hr.} = 180 \text{ MBH}$

\* Approximate BTU Value

# Part 1 Installation

## VII Initial Start Up/Adjustment Continued

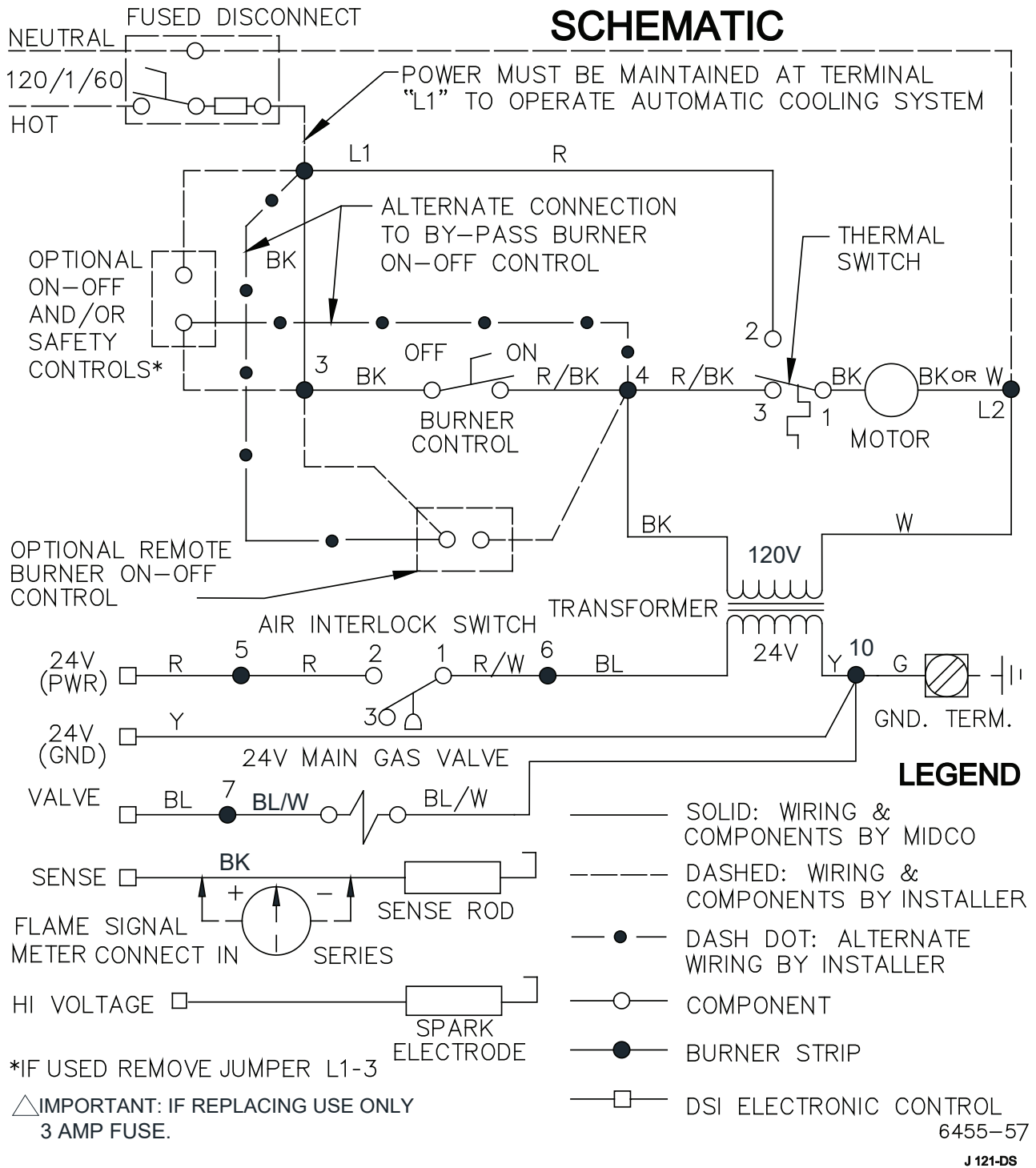

Figure 2A Wiring Diagram (6455-57)

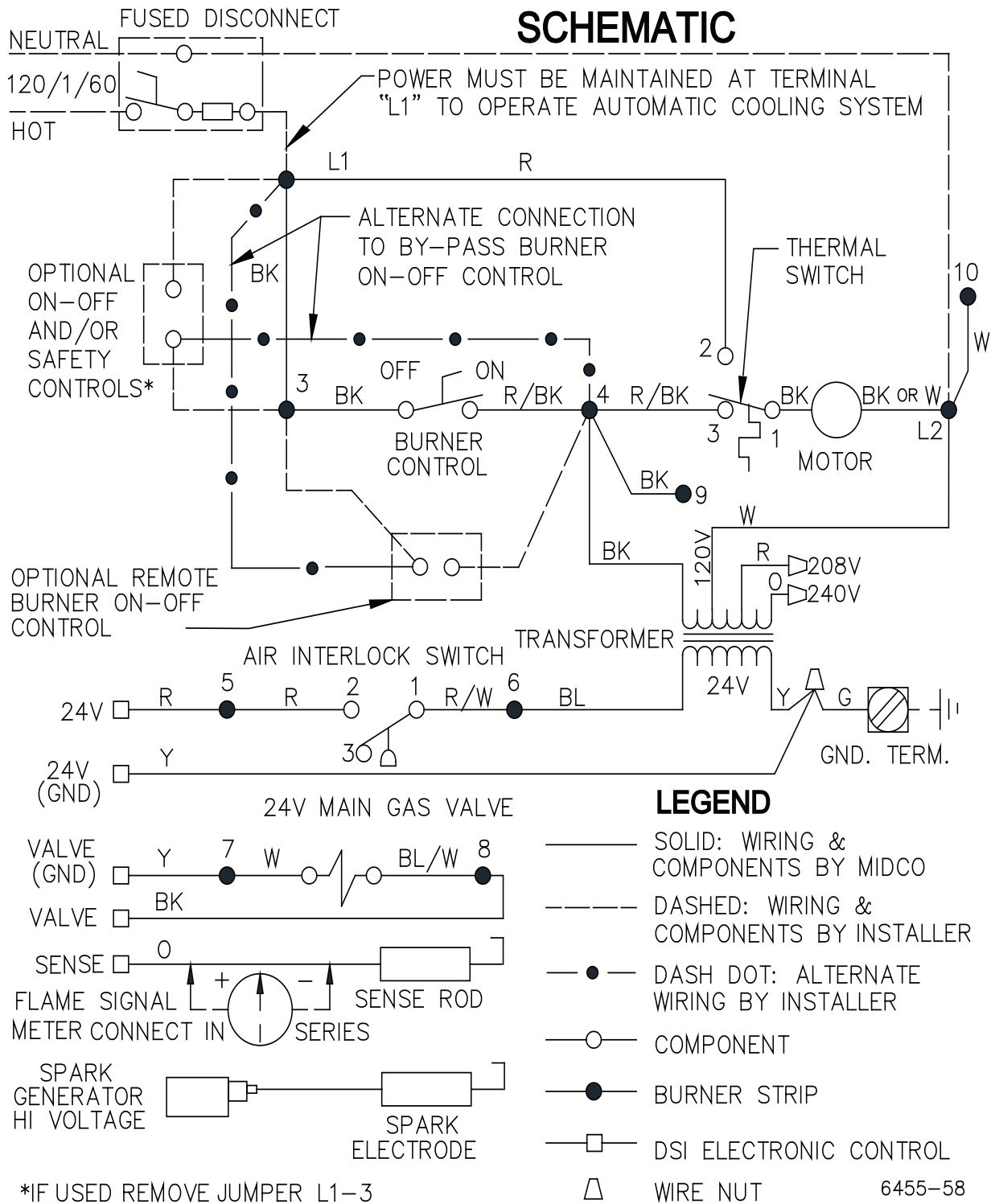
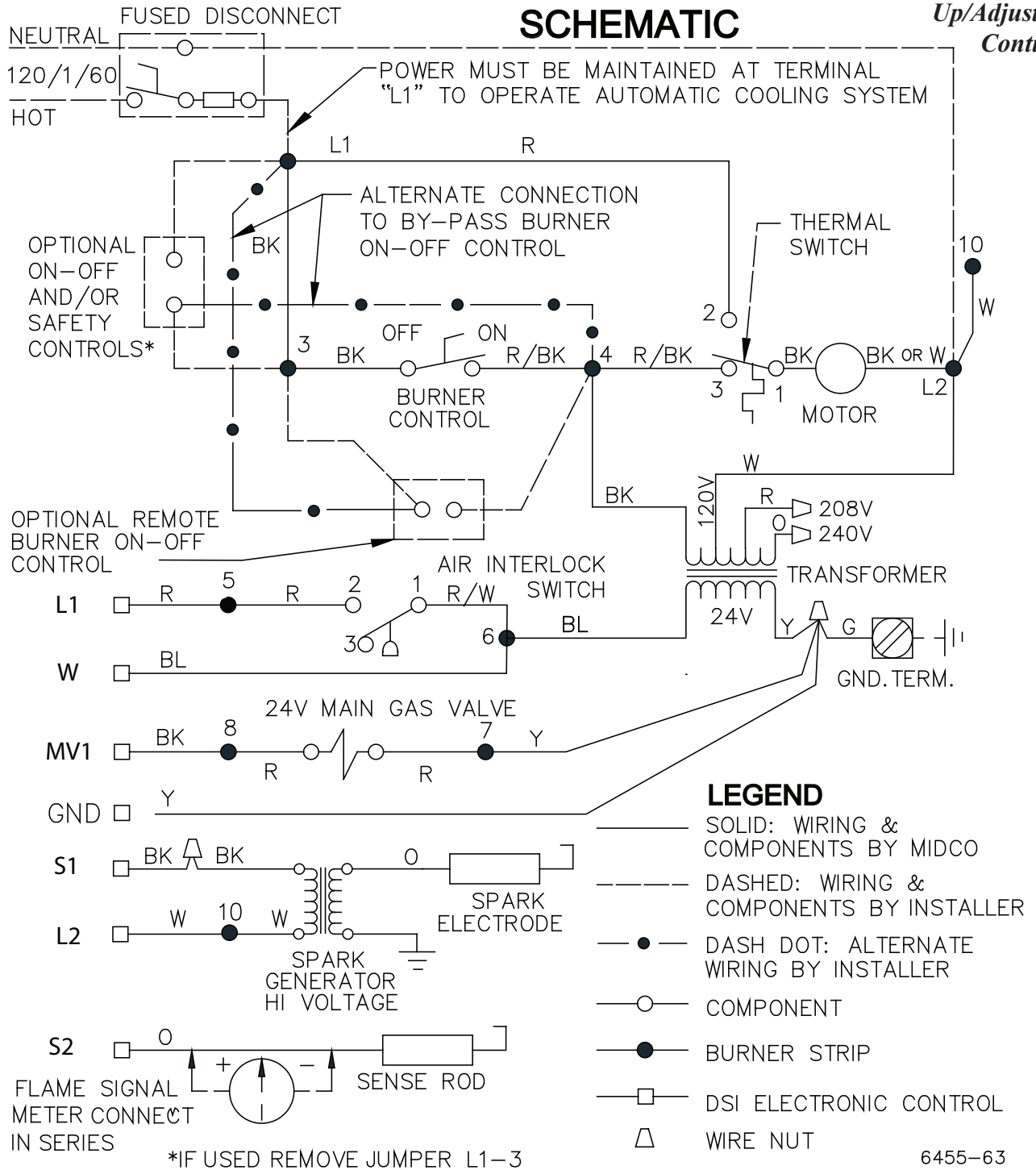

Figure 2B S89E Wiring Diagram (6455-58)





6455-63  
J121-DS/F-35-65

Figure 2D F-35-65 Fenwal Wiring Diagram (6455-63)

# Part 1 Installation

## VII Initial Start Up/Adjustment Continued

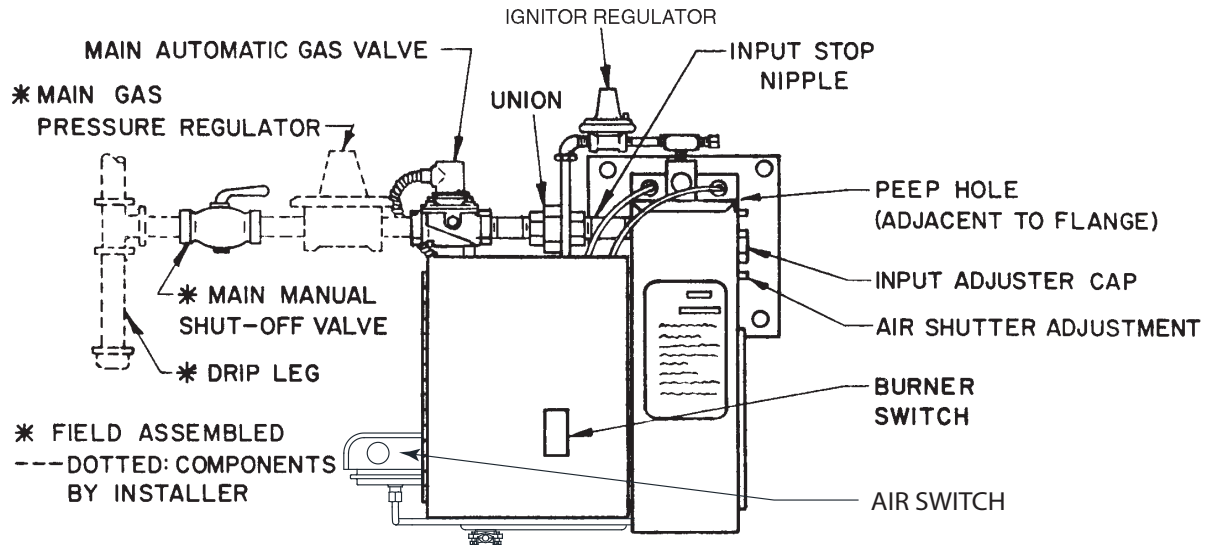

Figure 3 Control Components

Gas Pressure at Main Automatic Valve (Inches Water Column)

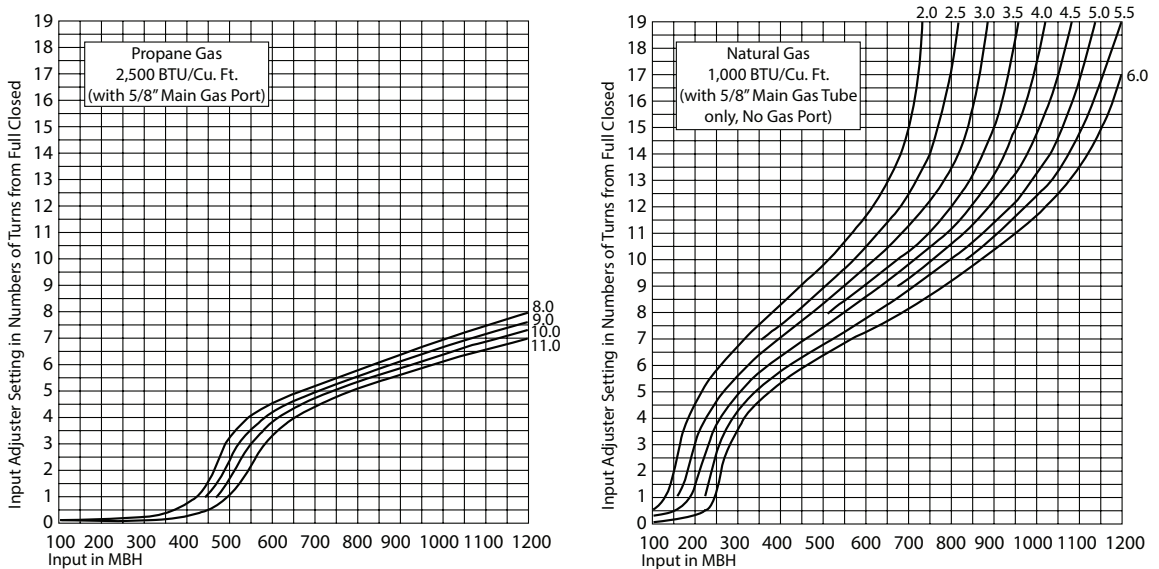

Table 2 Firing Rate Curves

13. Start and stop the burner several times to check its operation with the charging door open, and then with it closed. Remove any temporary Door Open bypasses installed in Step 6.
14. Test operation of any auxiliary operating and/or limit controls.
15. Load incinerator and make trial run. Confirm that the incineration chamber pressure stays within the range of 0 to minus 0.5" W.C.

**⚠ WARNING: When the incinerator is located inside a building and a draft control is used, check that there is no spillage of flue products from the draft control.**

16. To shut off: Turn Burner Switch or Timer off and close Main Manual Shut-Off Valve

**⚠ WARNING: BE SURE THAT THE MANUAL VALVE AND BURNER DISCONNECT SWITCH ARE TURNED OFF BEFORE ANY PARTS ARE REMOVED FOR SERVICE.**

The Ignitor and Regulator Assembly is removed as a unit. Disconnect the ignitor gas line and electrode wires, remove the two mounting screws and pull out the assembly.

- When the ignitor gas pressure is in the proper range (see Table 3) and the electrodes are adjusted to the dimensions shown in Figure 5, any ignition problems are usually caused by lint, dust, corrosion, cracked electrode insulators, foreign matter in the blast tube or deterioration of ignitor ports in Retention Plate.
- Ignitor trouble will be evidenced by failure of main burner ignition. It may cause frequent Electronic Control lockout. Check for dirt in the ignitor air and mixture passageways and check for obstructions in the ignitor ports. Also check electrode adjustments (see Figure 5). Replace any severely burned parts.
- Proper operation of the flame sensor rod can be checked by measuring the flame current. With the Electronic Control energized, a good reading should run steady 2 or more microamps.
- When servicing, clean the Ignitor Retention Plate ports and blow out the internal air and gas passages. Clean the Electrode Insulators and check them for hairline cracks. Also check the electrode ends and the Ground Barrier for serious corrosion or loss of metal. Replace any defective parts.
- Make sure that there is no debris in the Blast Tube that could short out the Spark or Flame Electrode.
- Clean the Ignitor Gas Orifice in Tee Orifice Fitting (see Figure 5) and check that the orifice size is correct per Table 3.
- Check that the electrode ends are positioned and that the gap between the end of each electrode and the ground barrier is spaced per Figure 5.
- Check that the Ignitor Air Deflector is at the correct angle (45°). See Figure 4.
- Inspect the electrode wire insulation for cracks or worn areas, or any contact with the burner frame. Dampness will facilitate electrical leakage to ground, which will cause ignition or flame signal failure.

| TYPE OF GAS | IGNITOR ORIFICE DIA. | RECOMMENDED IGNITOR GAS PRESSURE | IGNITOR GAS RATE |
|-------------|----------------------|----------------------------------|------------------|
| Natural     | .070 ( #50 DR )      | 3.5" W.C.                        | 13 MBH           |
| Propane     | .063 ( #52 DR )      | 3.5" W.C.                        | 15 MBH           |

*Table 3 Ignitor Firing Rate*

**SPARK TEST**—Main Manual Shut-Off Valve must be off. Place the Ignitor Assembly on top of the burner with the electrode ends visible and good metal to metal contact between the Ignitor Mounting Plate and the burner chassis.

- Connect the high voltage wire to the spark electrode. Spark should be visible during 6-second trial for ignition period and arc from the electrode end to the Ground Barrier. It should be audible and visible, though it is rather thin and difficult to see in bright light.

**⚠ CAUTION: Circuit has 30,000 volt open circuit potential.**

- If the spark is not audible or visible it is leaking directly to ground. Before removing electrodes, check to make sure voltage is available by positioning the spark wire 1/8" from the end of the electrode.
- **Disconnect Flame Electrode** wire and switch the high voltage wire to the flame electrode and repeat test for insulator leakage.

**⚠ CAUTION: Do not indiscriminately change the ignitor gas orifice size as ignition troubles are rarely cured in this manner. The ignitor utilizes a premixed gas/air mixture and, as the air input is relatively fixed, any adjustment to the gas/air ratio that might be required for a specific application should be made by careful adjustment of the ignitor regulator to vary its outlet gas pressure. Pressure adjustments must be made when the gas is flowing. If cleaning and electrode adjustment does not eliminate an ignition problem, further checks are required. Refer to Trouble Chart.**

The ignitor assembly as shipped is pre-set during factory fire-testing and normally needs no adjustment except in installations where the air shutter is full open. The ignitor should not be adjusted until it is confirmed that good light-offs are not possible with ignitor gas pressure adjustments only as described in Section VIII.

- The Air adjustment screw is located under a plug button in the Ignitor Block about 1/2" behind the Ignitor Orifice (refer to Figure 5). A 5/64 (.078) inch hexagon wrench is required for adjustment. Pry up the plug button to expose air adjustment screw. Adjust the screw up or down to find the best Flame Signal or until repeatable and stable light-offs are achieved. Ignitor airflow is decreased as the screw is turned clockwise, and increased as it is turned counter-clockwise. Generally 3 to 5 turns up from full closed (screw bottomed out) works best.
- When adjustments are completed, replace plug button to protect adjustment screw.

## Part 2 Service

### X Main Automatic Valve

The valve is a single function on-off type with automatic closing on current failure. Replace entire valve if valve fails to open when power is applied or if leakage is detected on standby.

### XI Blower Assembly

Model J121-DS is equipped with 1/6 HP split phase 3450 RPM motor. It may contain either a manual or auto-reset overload protector. It has no interlock, this function being performed by an Air Pressure Switch on the burner. The motor features permanently lubricated ball bearings that require no routine oiling maintenance.

- Cleaning of the blower wheel is usually the only service required. Need for cleaning is required if the inlet screen or blower wheel shows an accumulation of dust and lint. The motor air cooling vents should also be cleaned at this time.
- If the motor must be replaced, disconnect the motor wires from the burner terminal strip. Remove the blower inlet screen and blower wheel and remove the motor case bolt nuts and lock washers.
- When remounting the blower wheel, the distance from the wheel and the outside of the blower housing air inlet side plate should be 5/16".

### XII Thermal Switch

The Thermal Switch is a heat sensitive single pole double throw snap switch that energizes the blower motor to provide cooling air if, because of a heat back up through the burner when the motor is off, the temperature of the blower housing reaches 160° F. The thermal switch is not wired into the gas valve circuit and does not turn valve off when activated by heat back up.

- The switch mechanism is a bi-metallic disc that snaps over when it is heated to the set temperature. The switch is mounted so that the disc bears against the side plate of the blower housing.
- Testing the switch to prove that it is functional can be done by removing the ignitor assembly and blowing hot air through the opening toward the blower inlet. If hot air is not available, remove the switch and check for continuity. With the switch cool, there should be continuity between terminals 1 (black wire) and 3 (red/black wire). To simulate the "hot" condition, place the switch on a firm surface and apply finger pressure to the switch disc. When the disc "snaps", there should be continuity between terminals 1 and 2 (red wire).

### XIII Electronic Control System

The Electronic Control is a 24 volt AC, solid state electronic device that automatically ignites and monitors the flame. It has an integral high voltage transformer and, upon flame startup, applies high voltage to the spark electrode and 24V to the Main Automatic Gas Valve. When the flame is proven, the spark is terminated and the burner run continues.

- If the flame is not proven within 6 seconds, or if the proof of flame is lost during the burner run and not re-established within 6 seconds, the Control will shut off the Main Automatic Gas Valve and LOCK OUT. To reset the Control for restart, turn off the Burner Switch or Timer for at least 30 seconds and then turn back on.

- If the Electronic control is changed, the replacement must be identical as to the make and model number, or must be an authorized substitute.

**⚠ WARNING: Explosion hazard. Do not use this device if it gets wet. It can malfunction and cause serious injury or death. Replace any device that has been wet.**

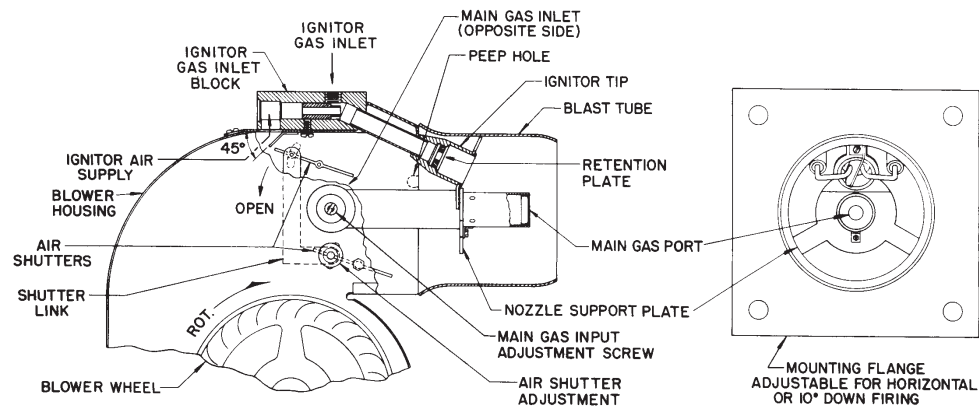

Figure 4 General Burner Assembly

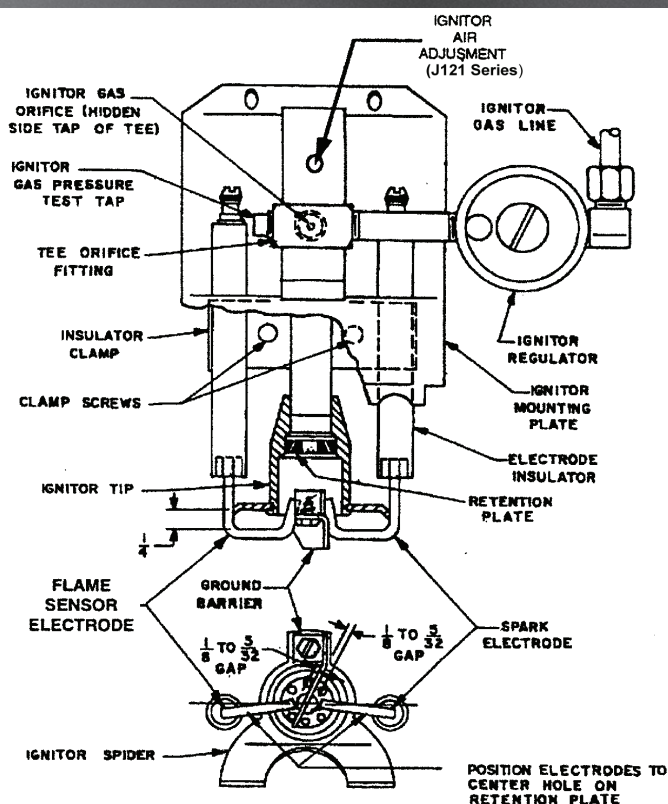

Figure 5 Ignitor and Flame Sensor Assembly

## Trouble Shooting

Make sure the thermostat and operating controls are calling for heat. Defective wiring or loose connections can simulate the component defects outlined below. Check associated wiring before replacing a component.

### ELECTRICAL AND FLAME CHECKS MUST BE MADE IN THE ORDER LISTED.

#### I. MOTOR WILL NOT RUN

A. Confirm 120V between strip terminals:

1. L2 & L1 no voltage - Fused disconnect off or Fuse open.
2. L2 & 3 no voltage - Optional on/off and/or safety controls open.
3. L2 & 4 no voltage - Burner Switch or Timer open and/or Remote Switch or Timer open.
4. L2 & Thermal Switch terminal 1 (black wire).
  - a. None - Thermal Switch is defective.
  - b. Yes - Motor is defective.

#### II. MOTOR RUNS CONTINUOUSLY, BUT NO FLAME- HOUSING COOL

A. Confirm that Main Manual Shut-Off Valve is open.

B. Check for 120V between strip terminals 4 and L2.

1. Yes - turn Burner Switch or Timer off for a minimum, of 30 seconds to **RESET** Electronic Control.
2. No voltage, Thermal Switch is defective.

C. Check for 24V\* between strip terminals 6 to 10. No voltage, transformer is defective.

D. Check for 24V\* between strip terminals 5 and 10. No voltage, air interlock switch is defective.

E. Check for 24V\* between Electronic Control 24 (PWR)/TH terminal and strip terminal 10. No voltage, red wire from terminal strip 5 is defective.

F. Check for 24V\* between Electronic Control 24 (GND)/GND terminal and strip terminal 10. No voltage, 24V yellow wire from strip terminal 10 is defective.

G. Turn burner control off for a minimum of 30 seconds to **RESET** Electronic Control for each of the following steps.

**⚠ CAUTION: Tests are valid only during the 6 second trial for ignition.**

1. Check for 24V\* between Electronic Control Valve terminal and strip terminal **10**. No voltage, Electronic Control or Fuse is defective.
2. Check for 24V\* between strip terminals **7** and **10**. No voltage, blue wire from strip terminal **7** is defective.
3. Check for ignition spark (spark length approximately 1/8"):
  - a. Between Electronic Control HI VOLTAGE terminal and earth ground. No spark, Electronic Control or Fuse is defective.
  - b. Between electrode wire and Spark Electrode. No Spark, Electrode wire is defective.
  - c. Check for spark between Spark Electrode and ground barrier. See Figure 5. If ignitor tip is not visible with burner mounted, but spark can be heard, continue with Step G4. If spark cannot be heard, refer to Section VIII IGNITOR AND REGULATOR ASSEMBLY for spark test.
4. Connect manometer to Ignitor Gas Pressures Test Tap and, during 6 second trial for ignition period, check gas pressure.
  - a. No pressure, confirm that pressure of at least 4" W.C. is available at inlet of automatic gas valve (connect manometer to valve upstream tap) and repeat Step G4. If still no ignitor gas pressure, valve is defective.
  - b. Ignitor gas pressure 3" to 4" W.C., continue with Step G5.
  - c. Adjust the ignitor regulator to 3.5" W.C. while gas is flowing.
5. Open charging door, make sure any **Door Open** interlock is bypassed, and repeat trial for ignition.
  - a. With flame on, close charging door and check combustion chamber pressure, burner peep hole can be used for access to obtain approximate reading. Make sure sensing tube extends into the combustion chamber for at 6". Pressure should be between 0" and minus 0.5" W.C. If pressure is on the high negative side of the range, increase the ignitor gas pressure to 4" or 5" W.C.
  - b. No flame, clean and test ignitor assembly per Section VIII IGNITOR AND REGULATOR ASSEMBLY

### III FLAME ON ONLY DURING 6-SECOND TRIAL FOR IGNITION

- A. With motor running check burner line voltage terminals for 120V as follows:
  1. Between strip terminals **L1** and **L2** - 120V: voltage OK.
  2. Between strip terminals **L1** and **GND.TERM.** - 120V: ground OK.
  3. Between strip terminals **L2** and **GND.TERM.** - no voltage: no back-feed neutral OK.
- B. Follow test procedure as specified in Step II G.
  1. Connect DC microamp meter in series with sense wire and Electronic Control SENSE terminal. With flame on, flame signal should be steady and at least 2 microamps. Check sense wire for continuity Adjust ignitor gas pressure to obtain acceptable signal and note gas pressure and signal strength for future reference.

### IV. SHORT FLAME

- A. Low gas pressure
- B. Air shutter open too far
- C. Input adjuster not set properly

### V. LONG HAZY FLAME

- A. High gas pressure
- B. Air shutter closed too far
- C. Insufficient free air in combustion chamber
- D. Dirty blower wheel
- E. Input adjuster not set properly

### VI. GAS FAILS TO SHUT OFF

- A. Defective automatic valve
- B. High gas pressure

\*Normal low voltage: Motor running - 24V minimum Automatic valve energized - 21V minimum

