

# Installation and Service Instructions

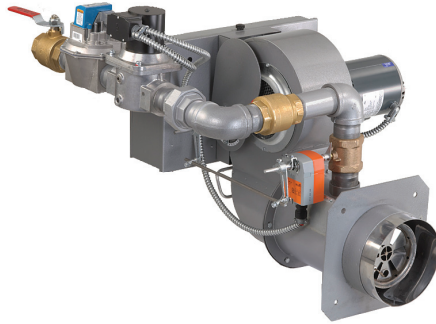

## Unipower MPG Series Gas Burners

- In the United States, installation must conform with local codes or in the absence of local codes, with the National Fuel Gas Code, ANSI Z223.1-latest edition available from American National Standard Institute. Further reference should be made to the recommendation of your fuel supplier.
- In Canada, installation must conform with local codes or in the absence of local codes, with Installation Codes for Gas Burning Appliances and Equipment, CGA Standard CAN/CGA 1-B-149.1 or 2.
- **⚠ WARNING: Additions, changes, conversions and service must be performed by an authorized Midco representative, service agency or the fuel supplier. Use only MIDCO specified and approved parts.**

- **INSTALLER:** Inform and demonstrate to the user the correct operation and maintenance of the gas utilization equipment. Inform the user of the hazards of storing flammable liquids and vapors in the vicinity of this gas utilization equipment and remove such hazards. Affix this manual and associated literature to the burner.

**CODE COMPLIANCE IS THE SOLE RESPONSIBILITY OF THE INSTALLER.**

- **USER:** Retain this manual for future reference. If other than routine service or maintenance as described in this manual and associated literature is required, contact a qualified service agency. **DO NOT ATTEMPT REPAIRS.** An inadvertent service error could result in a dangerous condition.

**AVOID ERROR IN PARTS SELECTION.** When ordering use complete MIDCO Part Number and Description. Furnish Burner Model Number, Bill of Material Number and Serial Number (if available) from the specification plate found on the product.

**IMPORTANT:** Availability of parts as well as specifications are subject to change without notice. Please consult factory for item availability.



**Midco**  
INTERNATIONAL

Midco® International Inc.  
4140 West Victoria Street  
Chicago, Illinois 60646  
toll free 866.705.0514  
tel 773.604.8700  
fax 773.604.4070  
web www.midcointernational.com  
e-mail sales@midcointernational.com

**⚠ WARNING: If the information in these instructions is not followed exactly, a fire or explosion may result, causing property damage, personal injury or death.**

Do not store or use gasoline or other flammable vapors and liquids in the vicinity of this or any other appliance.

**WHAT TO DO IF YOU SMELL GAS:**

- Do not try to light any appliance.
- Do not touch any electrical switch; do not use any phone in your building.
- Immediately phone your gas supplier from another building. Follow the gas supplier's instructions. If you cannot reach your gas supplier call the fire department.

Installation and service must be performed by a qualified installer, service agency or the gas supplier.

**BURNER MODEL:** \_\_\_\_\_

**BILL OF MATERIAL NUMBER:** \_\_\_\_\_

**SERIAL NUMBER #:** \_\_\_\_\_

**WIRING DIAGRAM:** \_\_\_\_\_

**FOR SERVICE CONTACT**

**Name:** \_\_\_\_\_

**Address:** \_\_\_\_\_

**Phone:** \_\_\_\_\_

**Date of Installation:** \_\_\_\_\_

**SAFETY INFORMATION TERMS:** The following terms are used to identify hazards, safety precaution of special notations and have standard meanings throughout this manual. They are printed in all capital letters using a bold type face as shown below, and preceded by the exclamation mark symbol. When you see the safety alert symbol and one of the safety information terms as shown below, be aware of the hazard potential.



**DANGER:** Identifies the most serious hazards which will result in severe personal injury or death.  
**WARNING:** Signifies a hazard that could result in personal injury or death.  
**CAUTION:** Identifies unsafe practices which would result in minor personal injury or product and property damage.



*Quality Designed for Proven Performance*



825  
8471 51  
Printed in USA

# Specifications

## Specifications <sup>1</sup>

Burner Style	Power Type Sensing			
Pilot Type	Intermittent;		Flame Rod Sensing, Spark Ignition (Standard)	
	Intermittent;		UV Sensing, Spark Ignition (Optional)	
	Interrupted;		Flame Rod Sensing, UV Flame Scanner (Optional)	
Pilot Safety	Instantaneous	Electronic Flame Safeguard		
Voltage	Standard			
Controls	120/1/60			
Motor	115/1/60			
	230/1/60 (Optional)			
U.L. Listed -U.L.C. Listed Non UL 220V / 50HZ - Contact Factory				
Models	Minimum	Maximum	Maximum	Inlet Gas Pressure
	Input <sup>1</sup>	Input <sup>1</sup>	Air	Required <sup>2</sup>
	MBH/HR *	MBH/HR *	SCFM <sup>3</sup>	Natural Propane
MPG 1.5G **	500	1500	325	4" W.C. <sup>4</sup> 4" W.C. <sup>4</sup>
MPG 2.5G **	850	2500	540	4" W.C. 4" W.C.
Burner Manifold Pressure <sup>1</sup>				Recommended
Models	Natural	Propane	Combustion	Motor HP Chamber
			(3450 RPM)	Size
MPG 1.5G	0.13 - 1.20" W.C.	0.80 - 0.70" W.C.	1/2	See Table 3
MPG 2.5G	0.09 - 0.80" W.C.	0.06 - 0.50" W.C.	3/4	See Table 3
<p>*1 MBH=1,000 BTU/HR  ** High Turn Down Models available - contact factory  1. Values given based on 0" W.C. firebox pressure, altitudes to 2,000 feet. Derate burner for altitudes over 2,000 feet by 4% for each 1,000 feet over sea level.  2. Maximum inlet pressure both gases: 14" W.C. Refer to Section VI <b>Piping</b> for high pressure.  3. SCFM=Standard Cubic Feet/Minute  4. Requires special valve train - contact factory</p>				

**Table 1: Burner Specifications**

Models	Minimum	Maximum Capacity in MBH at			Maximum	Maximum
	Firing	Combustion Chamber			Back	MBH * at
	Rate	Back Pressure			Pressure	Maximum
	MBH *	0" W.C.	.25" W.C.	.50" W.C.	in W.C.	Back Pressure
MPG 1.5G	500	1500	1500	1400	1.0"	1200
MPG 2.5G	850	2500	2500	2450	1.0"	2000
<p>*1 MBH=1,000 BTU/HR. See Table 6 for gas pressure and air shutter settings</p>						

**Table 2: Maximum Capacity at Specified Back Pressures**

The Midco power gas burner, MPG Series, is designed for firing natural gas or propane gas in most applications. The burner is a self-contained unit including a blower housing assembly, a burner gas manifold assembly, a burner cartridge, a flame safeguard, and a main and pilot gas train. The burner is easy to install, it includes mounting the burner to the gas utilization equipment, piping the main and pilot gas train and connecting the power supply. Before shipment every burner is operationally fire tested at the factory, for unassembled valve trains the pilot solenoid and ignition system is tested.

## Part 1 - Installation



**CAUTION: MPG-Series are not intended for outdoor installation and must be protected from excessive moisture. Provide adequate clearance for service and proper operation.**

### I Ventilation

• Open basements will generally allow sufficient air infiltration, so special provisions will seldom be required. If the heating plant is located in a separate furnace room or in an unusually tight basement, permanent means must be provided to supply an ample volume of fresh air for combustion and boiler room ventilation. A direct opening to the outside air should be provided sized on the basis of 1/2 square foot of free opening for each 1,000,000 BTU of burner rating when the vent connector is equipped with a barometric draft control, 11/2 square feet when equipped with a draft hood. If the ventilation opening is screened, it should be of 11/4" mesh.

- The opening should be located at least six feet above ground level to prevent accidental obstruction. If a direct opening to the outside air is not available, an amply sized air duct can be run to the nearest outside air source or if practical, open stairwells or building corridors connecting to an outside wall having a ventilating opening can be used for this purpose, provided that no possibility of accidental closure exists.
- While the spark ignition pilot system performs successfully under moderate or momentary back draft conditions, it is not intended for operation under sustained reverse draft, for example, in a building with large ventilating fans but with insufficient make-up air. Even if burner operation is successful under these conditions, they must be corrected to prevent the hazard of drawing flue gases into the building. Consult your local gas company when doubt exists concerning boiler room ventilation.

## I Ventilation Continued

- The heating system, both the gas utilization equipment and the distribution system, should be in good operating conditions and sufficient to properly heat the building. It should be determined if any serious faults are present that would cause excessive fuel consumption, unsafe operation or improper heating, and measures taken to correct them.

Firing door catches should be filed off or otherwise arranged so that the door will open easily to relieve pressure. No positive catches should be used. The use of a spring-type door holder is recommended.

## II Preparation of the Gas Utilization Equipment

- Mount the burner to the gas utilization equipment. A tight seal between the mounting flange and the front plate should be accomplished using the supplied high temperature rope. When installing the gas burner the distance from the flange to the blast tube edge should be the same as the gas utilization equipment wall thickness plus the flange gasket or rope thickness. That means the burner blast tube will be flush with the inner chamber wall after the burner has been installed. If the blast tube is extended into the combustion chamber possible damage to the burner may happen. See Figure 1 & 2 for reference.

## III Combustion Chamber

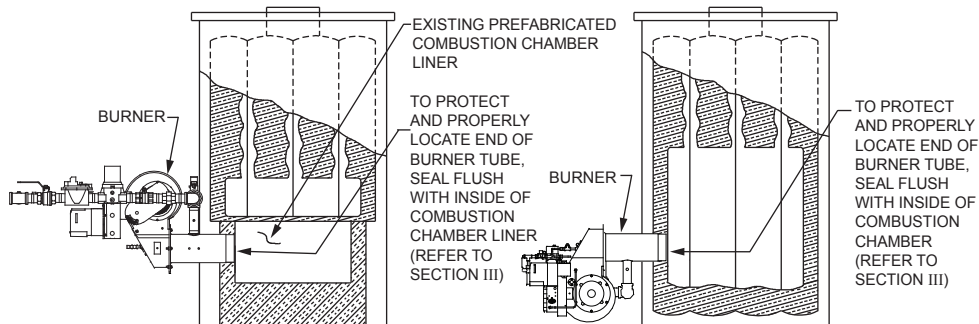

**Figure 1:** Dry Base Boiler with Combustion Chamber Liner (Warm Air Furnace Construction is Similar)

**Figure 2:** Wet Base Boiler with Unlined Combustion Chamber

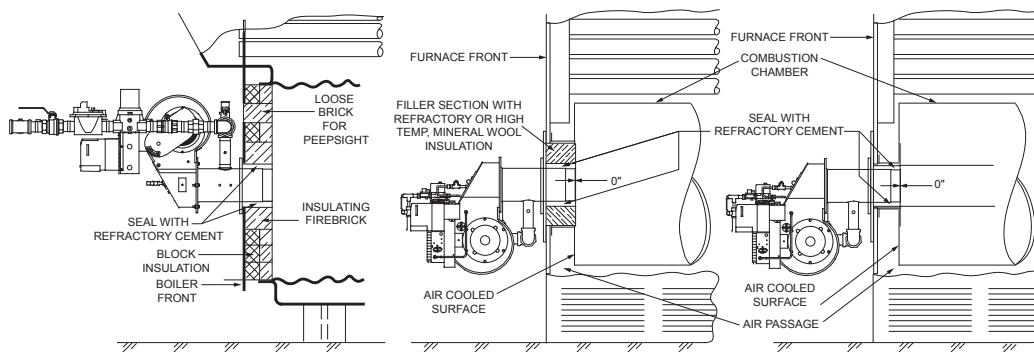

**Figure 3:** Scotch Marine Boiler

**Figure 4:** Warm Air Furnaces

# Part 1 Installation

## III Combustion Chamber Continued

- The MPG gas burner is designed for "in-shot" firing. It can be fired into the ash pit of a boiler designed for solid fuels, or it can be fired into the primary heat exchanger of a boiler designed for liquid or gaseous fuels. The ash pit installation requires a refractory lining.
- The combustion chamber serves to contain and promote combustion and to protect non-heat exchange surfaces from direct flame contact. Built-up combustion chambers should be made of 2600° insulating firebrick. As an alternative, a monolithic floor can be cast in place, using a high temperature (2400°) light weight insulating refractory. Check with your supplier to determine the thickness which will yield equivalent insulating qualities.
- The combustion chamber sizes given in Table 3 are based on the maximum rated burner capacity. If the input is to be permanently set at a reduced rate the combustion chamber floor area can be reduced proportionately to the proposed input, with the length as closely proportioned to twice the width as possible.
- Where recommended size combustion chambers (225,000 BTU/sq. ft.) can be accommodated, the type of construction shown in Figure 1 should be used. If lack of space prohibits use of this construction, higher BTU values per square foot can be allowed for by using the constructions shown in Figures 2 and 3.
- The back wall of the combustion chamber should be carried 2 or 3 courses higher and overhung to deflect the flames from direct impingement on the rear heat exchanger surface. Hard firebrick should be used to prevent erosion of the brick by high velocity gases.
- The burner is equipped with a mounting flange for direct attachment to the boiler front. The burner nozzle must not extend into the combustion chamber. It should be sealed into the opening as shown in Figures 1 - 4.
- The refractory lined combustion chamber can be omitted in "Scotch Marine" and "Steam Generator" boilers or warm air furnaces that do not include ash pits. The burner is fired directly into the heat exchanger, requiring no refractory unless the combustion chamber is so short that flame would impinge excessively on the rear heat exchanger wall (this is particularly important in a warm air furnace). Refractory protection is recommended if the length of the primary chamber is less than 20% larger than the length given in Table 3. In any case, the burner entry wall must be refractory lined if it is not a heat exchanger surface.

## IV Chimney, Vent Connector and Draft Control

Gas Input MBH/Hr	Width/Height"	Length "
500	12"	26"
1000	15"	34"
1500	18"	42"
2000	21"	50"
2500	24"	58"

**Table 3:** Recommended Combustion Chamber Minimum Required Dimension

Max Input MBH/Hr	Flue Pipe Diameter "
700	9"
950	10"
1400	12"
1950	14"
2500	16"

**Table 4:** Recommended Size of Flue Pipe and Chimney - Based on Maximum Height of 15' and Lateral Run of 15'

**NOTE:** For actual vent diameter information refer to the National Fuel Gas Code Handbook - Latest Edition

- ⚠ WARNING:** The chimney shall be inspected for unsafe conditions such as deteriorated masonry and excessive soot or other blockage or potential blockage. Installation must conform with local codes or in the absence of local codes with NFPA, ANSI Z223.1-latest edition.
- ⚠ WARNING:** No movable vent connector damper is permitted on any power gas burner installation. The chimney should be inspected for unsafe conditions such as deteriorated masonry and excessive soot or other blockage or potential blockage. Check your local authorities for regulations covering barometric draft regulators on gas equipment.
- ⚠ WARNING:** The vent connector shall not be connected to a chimney already venting solid fuel burning equipment, an incinerator or an open fire place.
- The MPG burner does not depend on chimney draft. Combustion air is supplied by the forced air blower, which is sufficient to supply adequate air for any normal application. This reduces the function of the chimney to remove of flue products from the boiler. A chimney height of 15' above the boiler flue outlet will generally prove ample if the recommended or larger vent connector and chimney diameters are used. The chimney must of course, extend several feet over the roof of the building, or adjacent buildings. Vent connector material should be 24 gauge or heavier steel, galvanized to resist corrosion. The horizontal run of vent connector should be pitched upward from the appliance flue outlet at least 1/4" to the foot. Avoid excess elbows or other constructional features that would create excessive resistance to flow of flue products. Fasten joints with sheet metal screws to prevent sagging. The vent connector should be maintained at least 6" from combustible building materials; more if it is uninsulated. Where it passes through partitions constructed of combustible materials a ventilated thimble should be used. Refer to your local building codes. The vent connector should be firmly cemented into the chimney but must not extend

## IV Chimney, Vent Connector and Draft Control Continued

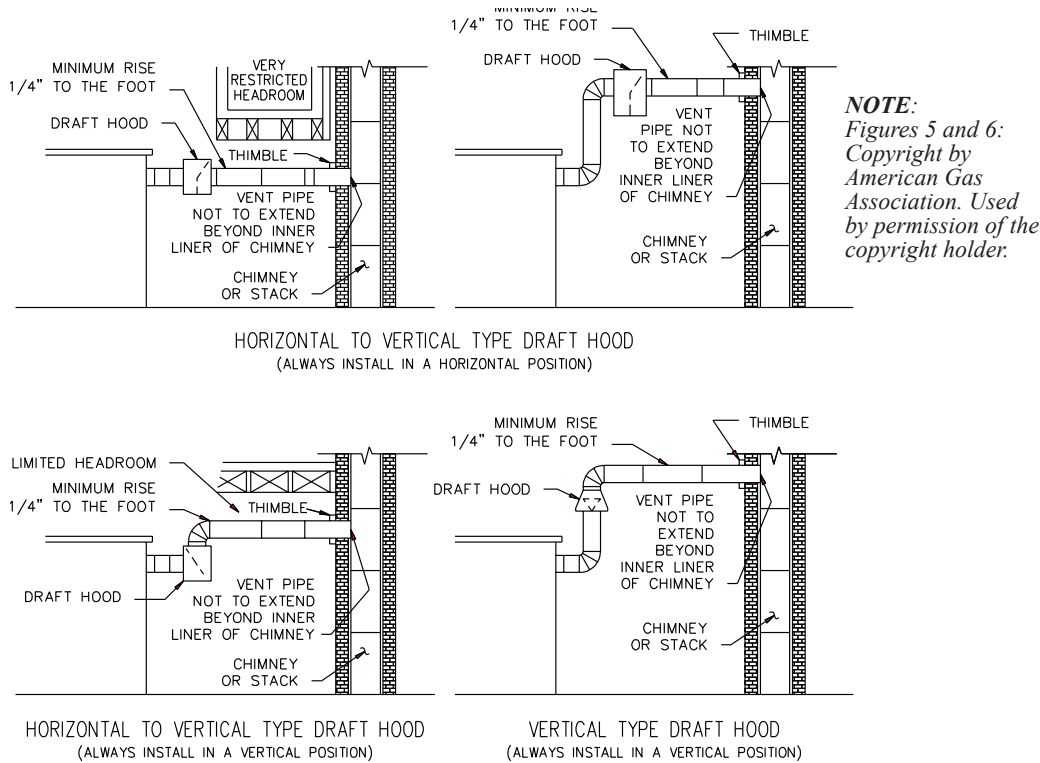

**Figure 5: Recommended Locations for Draft Hoods**

beyond the inner face. Where two or more appliances use the same chimney, be sure not to enter the chimney with both flue pipes at the same level.

- Do not arbitrarily reduce the vent connector size, since a back pressure can build up, leading to possible leakage of flue products into the room.
- Chimney construction can be either of brick, preferably tile lined, or of steel. Joints in the chimney should be smooth and leak free to prevent uncontrollable air infiltration. They should be made so that condensation if any, will not collect in the joints or leak to the outside.
- If the vent connector must be extra long, the area of the pipe and chimney should be increased or the chimney height must be increased, or both. Never allow the horizontal length of the vent connector to exceed the height of the chimney.

- Two kinds of draft control are acceptable; an A.G.A. type draft hood as illustrated in Figure 5, or a barometric damper as shown in Figure 6. Use of a draft hood is usually limited to burners with lower range capacities, while a barometric draft control is suitable for all capacities. Application should depend on the requirements of the installation.

- If a draft hood is used, it should be of the same size as the vent connector and is free swinging without interference from surrounding objects so that the velocity pressure of the flue gases does not interfere with its operation. See Figure 5 for proper installation.

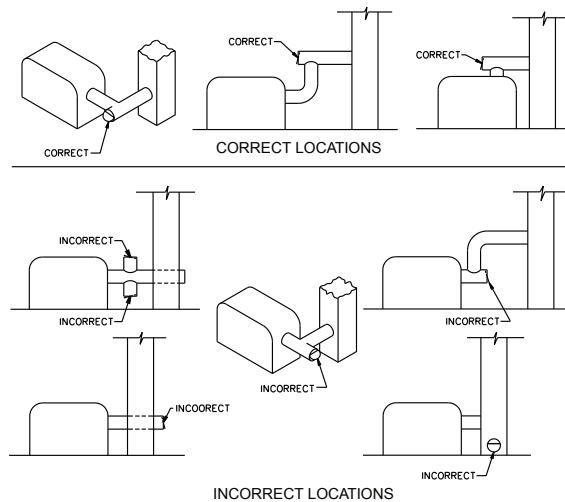

**Figure 6: Location for Barometric Draft Regulators**

*Note: Figures 5 and 6 : Copyright by American Gas Association. Used by permission of the copyright holder*

# Part 1 Installation

## IV Chimney, Vent Connector and Draft Control Continued

When any vent connector passes through a partition the draft control must be located in the same room as the heating appliance. A device which will automatically shut off gas to the burner in the event of sustained backdraft is recommended if such backdraft might adversely affect burner operation or if flue gas spillage might introduce a hazard. If such a device is used, it shall be of the listed type and installed and adjusted by a qualified service technician in accordance with the manufacturer's instructions

## V Electrical

Electrical installation must be made in accordance with the United States to National Electric Code, ANSI/NFPA No.70-latest edition or Canadian Electrical Code, Part 1, CSA Standard C22.1. and applicable local code. If the burner is a part of a gas utilization equipment system, check the wiring diagram as supplied by the manufacturer.

The burner when installed, must be wired and grounded in accordance with local codes or in the absence of local codes, with the National Electric Code ANSI/NFPA No. 70-latest edition. In Canada, refer to CSA Standard C22.1, "Canadian Electrical Code Part 1".

**CAUTION: Refer to the wiring diagram included with each burner.**

When wiring, be sure that the electrical power take-off is connected to a permanently live circuit and use multiple 14 gage copper wire conductors. Provide a fused disconnect switch in the burner circuit. Each installation must include a limit control to guard against excess temperature or steam pressure. Steam or vapor systems will require a low water cut-off.

**WARNING: Wiring shown is for standard burners. Consult the factory for specific wiring and have the Bill of Material Number ready when calling.**

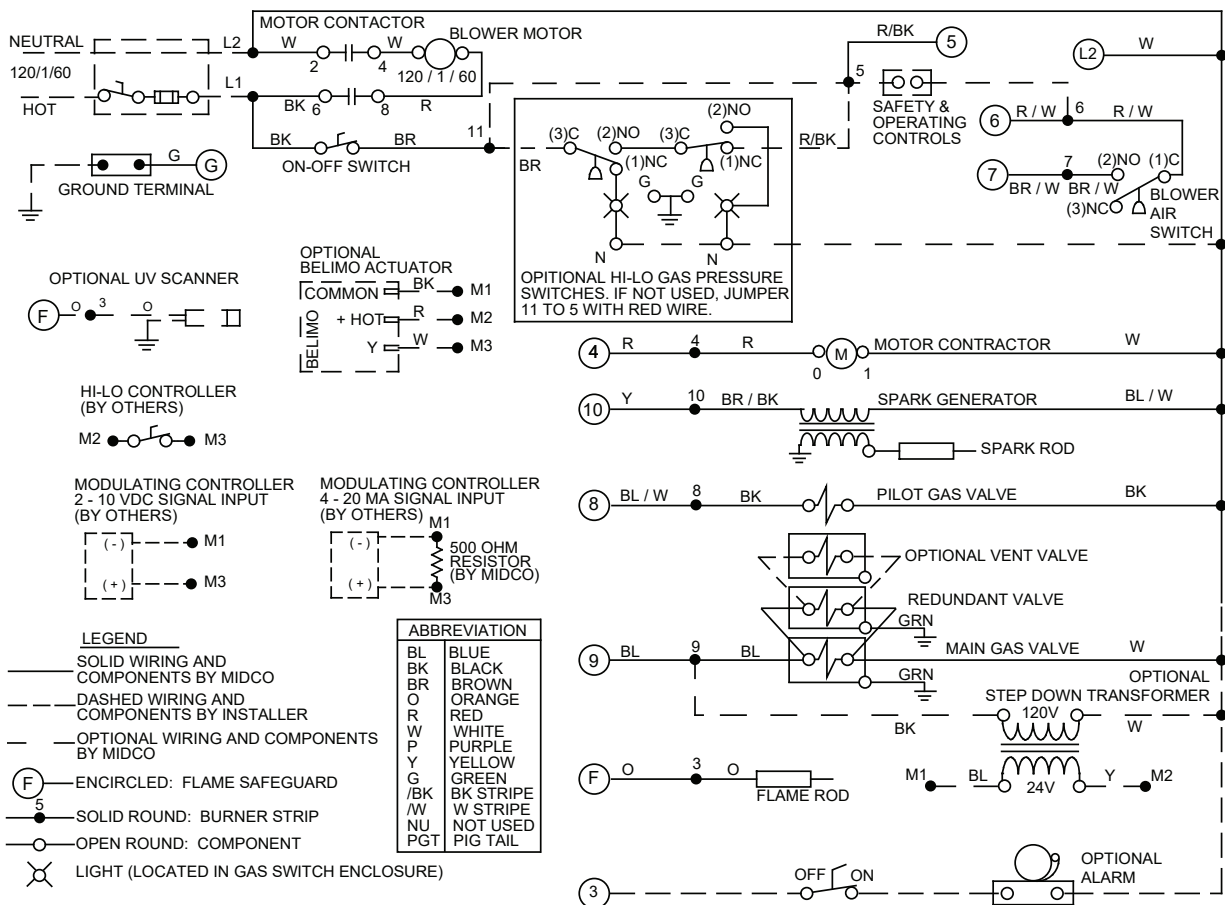

Figure 7A: Wiring Diagram for MPG 1.5 and MPG 2.5 - 120V - Honeywell

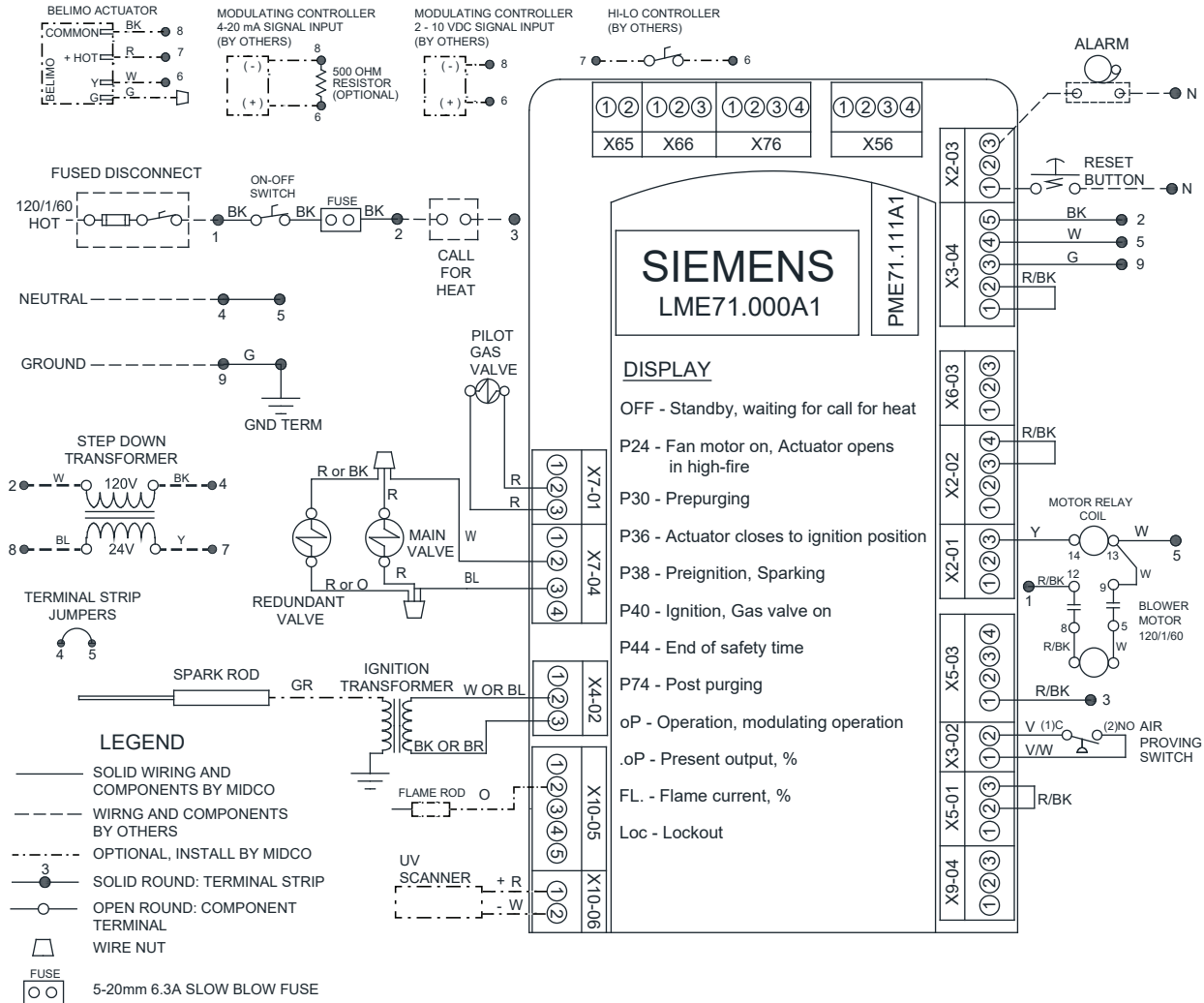

Figure 7B: Wiring Diagram for MPG 1.5 - 120V - Siemens

# Part 1 Installation

## V Electrical Continued

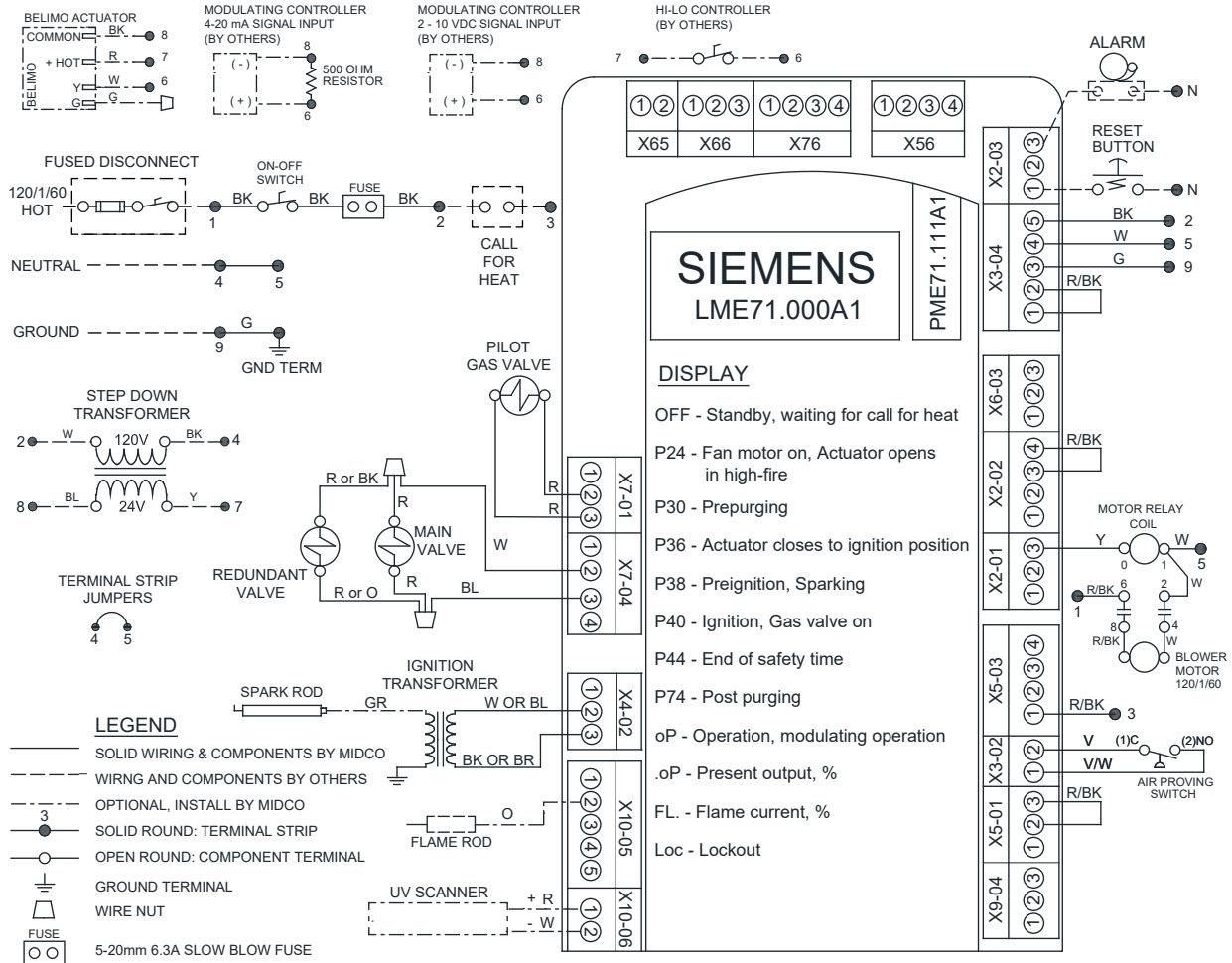

Figure 7C : Wiring Diagram for MPG 2.5 - 120V - Siemens

## VI Piping

- Piping must comply with national and local codes.
- Provide a sediment trap, manual safety shut-off valve and union in piping close to burner as shown in Figure 8:
- To obtain the maximum firing rate of the burner, the fuel gas supply piping must be sized to provide a minimum of 5" W.C. pressure to the inlet of the combination valve when the burner and all other gas appliances are on based on valve train size.  
For the usual low pressure gas supply system, 5" to 14" W.C. NATURAL (11" to 14" W.C. PROPANE) use Table 5 to find the recommended gas supply line size.
- Piping follows normal practices and should be connected to the burner in the manner shown in Figure 8. If the piping must be rearranged because of space limitations be sure to carry out the sequence of components illustrated. While the pilot regulator can be mounted in any position, the main regulator should be mounted upright and in a horizontal run of pipe.
- Run full size pipe or tubing from regulator vent openings to outside of building. Provide no traps in the vent lines and terminate away from all doors and windows; also make provisions for keeping rain and foreign objects from entering the vent piping.
- When high supply gas pressure is encountered, as in the case in many industrial plants, the gas line size can be reduced to allow for a greater pressure drop; however, the size must be sufficient to deliver the necessary burner gas inlet pressure.

**CAUTION:** High gas pressure supply lines require the proper pressure reducing regulators. Install two separate high pressure regulators, of the Tight Shut-Off type upstream of the low pressure regulators. One sized for main gas input, and one suitable for the minimum flow regulating capacity of the pilot.

▪ The high pressure regulators may be substituted for the low pressure regulators. If high pressure regulators are used as substitutes, they must be adjustable down to a minimum of 2" W.C. outlet pressure for the pilot and 5" W.C. for the main gas. They must be adjustable down to the maximum burner inlet pressure rating (14" W.C.).

**⚠ DANGER: Explosion hazard.**  
**Do not use oxygen for pressure testing. An explosion could occur during initial start-up.**

▪ When the gas supply line is about to be put into service it must be tested to insure that it is gas tight. Use air or inert gas under pressure and test with soap and water or other liquids to locate leaks.

**⚠ CAUTION: Because it is difficult to accurately control pressure, disconnect all low pressure (14" W.C. max.) components (main and pilot) during supply pipe leak testing. Exposing low pressure regulators and valves to a pressure over 1/2 PSIG (14" W.C.) will damage components and void their warranties.**

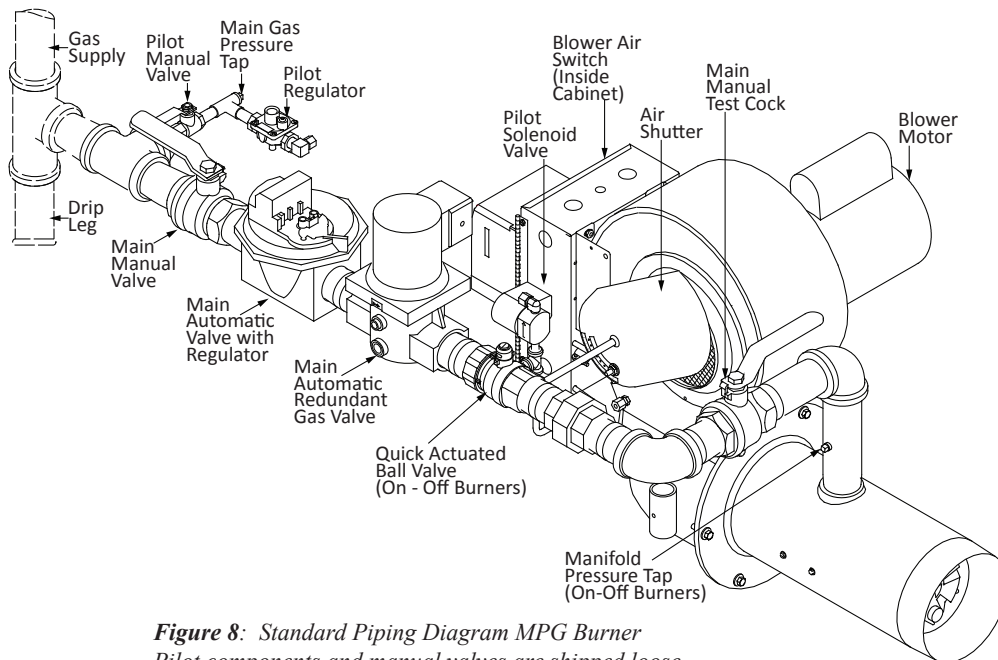

**Figure 8: Standard Piping Diagram MPG Burner**  
*Pilot components and manual valves are shipped loose*

**⚠ CAUTION: Do not exceed maximum rated capacity of burner model-See Tables 1 & 2.**

▪ Before gas is introduced to the system, a check must be made to see that there are no open fittings and to make sure the burner main and pilot manual valves are closed. After checking above, purge the gas line up to the burner inlet. Purging the air from the gas supply line at this step will expedite the first light-off

**⚠ CAUTION: Purge outside the building. Do not purge into the gas utilization equipment combustion chamber.**

Pipe Size	Type of Gas	Approximate Capacity - MBH				
		Pipe Length				
		20	40	60	100	200
1 1/4	Natural	730	500	400	300	
1 1/4	Propane	1150	785	630	480	330
1 1/2	Natural	1100	760	610	460	320
1 1/2	Propane	1730	1200	960	725	500
2	Natural	2100	1450	1150	870	610
2	Propane	2500	2280	1800	1370	960
2 1/2	Natural	2500	2300	1850	1400	980
2 1/2	Propane	2500	2500	2500	2200	1550
3	Natural	2500	2500	2500	2500	1700
3	Propane	2500	2500	2500	2500	2500

*For actual Capacities shown are for a total pressure drop of 0.3" W.C. For 0.5" W.C. pressure drop, multiply capacity shown by 1.3. Propane capacities shown are for a total pressure drop of 0.5" W.C. For higher permissible pressure drops, consult your gas supplier. Source: Gas Engineers Handbook - 1974*

**Table 5: Schedule 40 NPT Pipe-Capacity Chart**

# Part 1 Installation

## VII Main Gas Input Selection

Burners are approved for use with NATURAL gas or PROPANE gas and should be used only with the gas specified on the rating plate.

- The gas input should be set at the heating rate determined by the building heat loss and/or heating plant survey, but not exceeding the rated maximum input of the gas utilization equipment.

### MPG1.5G with 1.5" train (On-Off) Gas Flow & Air Shutter Setting

Firing Rate (MBH/Hr)*	500	700	800	900	1000	1100	1200	1300	1400	1500
Natural Gas Manifold Pressure " W.C. **	0.13	0.26	0.34	0.43	0.53	0.65	0.77	0.90	1.05	1.20
Propane Gas Manifold Pressure " W.C. **	0.08	0.15	0.20	0.25	0.31	0.38	0.45	0.53	0.61	0.70
Air Shutter Position	0.0	0.0	0.2	0.3	0.5	0.8	1.4	2.3	4.0	6.8

### MPG2.5G with 2" train (On-Off) Gas Flow & Air Shutter Setting

Firing Rate (MBH/Hr)*	850	1500	1600	1700	1800	1900	2000	2100	2200	2300	2400	2500
Natural Gas Manifold Pressure " W.C. **	0.09	0.29	0.33	0.37	0.41	0.46	0.51	0.56	0.62	0.68	0.74	0.80
Propane Gas Manifold Pressure " W.C. **	0.06	0.18	0.20	0.23	0.26	0.29	0.32	0.35	0.39	0.42	0.46	0.50
Air Shutter Position	0.0	0.7	0.9	1.1	1.3	1.6	1.8	2.0	2.2	2.5	2.9	3.5

\* 1 MBH=1,000 BTU/HR

\*\* Based on zero chamber pressure at sea level (Chamber pressure can be measured at pilot gas pressure tap with pilot gas off)

Table 6: Manifold Gas Pressure and Air Shutter Settings - On-Off

### MPG1.5G with 1.5" train (2 Stage and Full Modulation) Gas Flow & Air Shutter Setting

Firing Rate (MBH/Hr) *	500	600	700	800	900	1000	1100	1200	1300	1400	1500
Natural gas pressure drop between 2nd valve and main gas flow control valve, " W.C. **	0.06	0.09	0.12	0.16	0.20	0.24	0.30	0.35	0.41	0.48	0.55
Propane gas pressure drop between 2nd valve and main gas flow control valve, " W.C. **	0.03	0.05	0.07	0.09	0.11	0.13	0.16	0.19	0.23	0.26	0.30
Air Shutter Position	0.0	0.0	0.0	0.2	0.3	0.5	0.8	1.4	2.3	4.0	6.8

### MPG2.5G with 2" train (2 Stage and Full Modulation) Gas Flow & Air Shutter Setting

Firing Rate (MBH/Hr) *	850	900	1100	1300	1500	1700	1900	2100	1300	2500
Natural gas pressure drop between 2nd valve and main gas flow control valve, " W.C. **	0.06	0.09	0.12	0.16	0.20	0.24	0.30	0.35	0.41	0.48
Propane gas pressure drop between 2nd valve and main gas flow control valve, " W.C. **	0.03	0.05	0.07	0.09	0.11	0.13	0.16	0.19	0.23	0.26
Air Shutter Position	0.0	0.0	0.0	0.2	0.3	0.5	0.8	1.4	2.3	4.0

\* 1 MBH=1,000 BTU/HR

\*\* Based on zero chamber pressure at sea level (Chamber pressure can be measured at pilot gas pressure tap with pilot gas off)

Table 7: Manifold Gas Pressure and Air Shutter Settings - 2 Stage and Full Mod

## VIII Initial Start-up /Adjustment On-Off Burners

- 1) Check the gas piping for leaks. If a leak is detected it should be located with a soap suds test and repaired.
- 2) Make sure that the burner main and pilot gas lines are both completely purged of air. Don't purge into the combustion chamber. Purge outside the building.
- 3) Make sure the burner power switch is off, manual valves of main gas and pilot gas are closed, and motor is free to rotate.
- 4) Make the proper settings on all limit controls and set controller to call for heat.
- 5) Set air shutter to the correct position according to Table 6 and tighten in place.
- 6) Energize Power On-Off switch, and allow motor to run through the pre-purge of 30 seconds and the pilot ignition cycle. Check the blower wheel for proper rotation. Viewing from blower inlet side, rotation should be counter-clockwise. With no pilot gas, the flame safeguard will lock out, stopping the motor.
- 7) Wait one minute, reset the flame safeguard and open the pilot manual valve with main manual valve still closed. When pre-purge period of 30 seconds has been completed the pilot solenoid valve and spark generator will be energized. The pilot should light and the flame rod senses pilot flame. Adjust the pilot gas pressure to reach a strong and stable pilot flame according to Table 8. Test for ignition and stability of pilot several times.
- 8) Turn off Power On-Off switch. Open Main Manual Shut-off Valve half way.
- 9) Find the required main gas manifold pressure from the Table 6. Use a Digital Gas Manometer to measure the main gas manifold pressure.
- 10) Turn on Power On-Off switch. The burner will start and go through the 30 second pre-purge period and you should have pilot ignition and then the Main flame should light
- 11) Slowly open the Main Manual Shut-off Valve and adjust the gas pressure regulator on the Main Gas Combination Valve, until the main gas manifold pressure reaches the required value as shown in Table 6 and the Main Manual Shut-off Valve is wide open.
- 12) Check the emissions in the flue with a Gas Analyzer, adjust the Air Shutter until the O<sub>2</sub> level of flue gas is approximately 3.5-4.5 %.
- 13) Cycle the burner on and off several times and check for Pilot ignition, Main gas ignition, main gas manifold pressure and O<sub>2</sub>, CO<sub>2</sub>, and CO readings.

For Hi-Low and Full Mod startup instructions see section XVII.

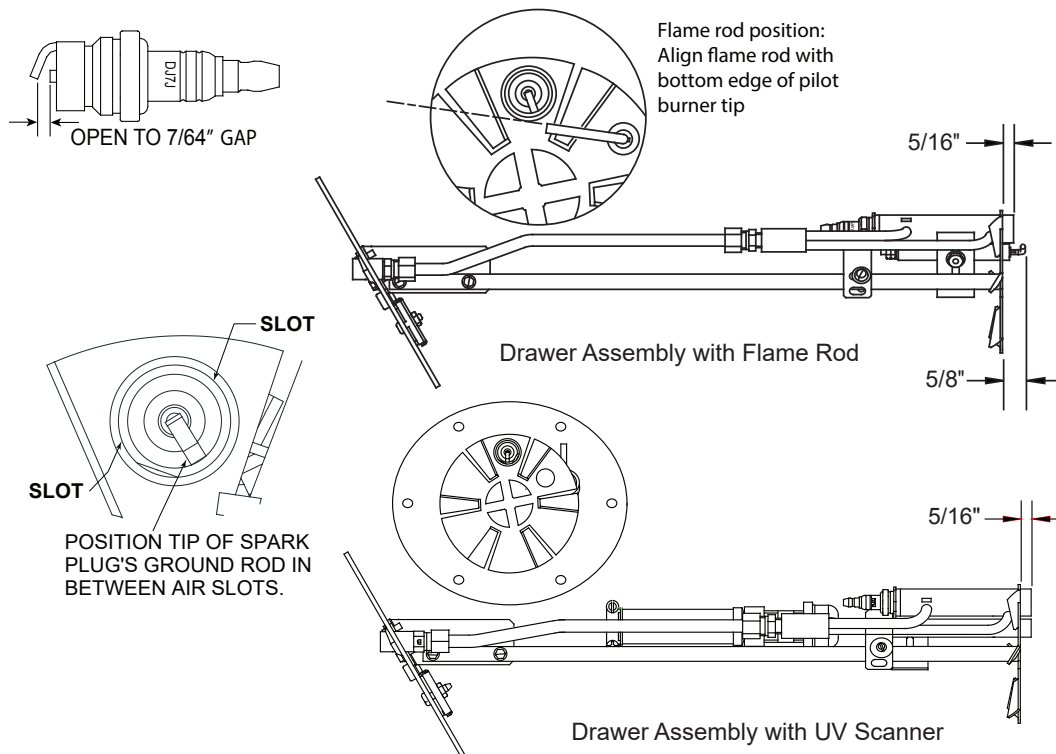

Figure 9: Drawer Assembly MPG Burner

# Part 1 Installation

## IX Blower and Motor

- The blower functions to supply a constant and positive supply of air for complete combustion. Air volume is controlled by an adjustable shutter in the blower inlet.
- No routine service is necessary on the blower other than occasionally cleaning the blower wheel. If the blower wheel must be replaced, be sure to check the replacement for proper rotation. The concave sides of the blades must face the blower outlet, and rotation of the wheel must be toward the outlet. Motor sizes and specifications are given in Table 1. All motors contain integral motor overload protection, usually manual, occasionally automatic reset.
- Proof of blower operation is provided by the diaphragm air switch, which must close its contacts and maintain them closed when the blower is running. In case of malfunction, the diaphragm air switch must be replaced.
- The pilot gas pressure will be measured at the outlet of pilot gas solenoid valve.

Model	Orifice Type	Orifice Size "	Drill Size	Pilot Gas Pressure
On-Off	A	0.11"	#35	2.0"-3.5"
Low Fire Start (Full Mod and 2-Stage)	B	0.076"	#48	2.0"-3.5"

## X Gas Pressure Regulator

- A combination integrated redundant main gas valve with an integrated gas pressure regulator is used on the standard MPG burner.
- The gas pressure regulator is used to automatically reduce and maintain constant gas pressure to the burner. To vary the outlet pressure, remove the seal cap for access to the adjusting screw. Turning the screw clockwise will increase outlet pressure, counter-clockwise will decrease outlet pressure.
  - Maximum and minimum allowable gas pressures are shown in Table 1.

## XI Main Automatic Valves

**Note:** All burners are equipped with dual valves. Burner construction for special codes and/or insurance requirements such as Factory Mutual or Industrial Risk Insurers (GAP) may require alternate construction. (Refer to Section XVI **Special Equipment.**)

## XII Diaphragm Main Automatic Valve

- The Honeywell diaphragm valve supplied on standard burners is of the slow opening, fast closing type. Closing force combines a gas pressure differential, diaphragm weight and spring.
- When the controller is not calling for heat, the coil is de-energized. The plunger of the three way actuator is in the down position, so that the bleed is closed and the supply port is open. Gas flows to the top diaphragm, causing the gas pressure and spring to hold the valve closed.
- With a call for heat, the flame safeguard energizes the coil. This pulls the plunger to the up position, opening the bleed valve and closing the supply port. The gas then bleeds off the top of the diaphragm, allowing the gas pressure below to lift the diaphragm, and open the valve. When all the gas has bled off the top of the diaphragm, the valve is fully opened. In the event of a power failure during operation, the valve will close. Normal operation will resume upon restoration of power.
- For general service, tests for gas tightness and proper operation will suffice. If leakage is observed, replace valve. If the valve will not open, make sure that normal gas pressure is available at the valve, the bleed line is unobstructed and power is available at the terminals.
- If the valve fails to close, make sure power is off at the terminals and gas flow is in the direction of the arrow on the valve body. When a malfunction is found to be caused by the valve operator head, the entire valve must be replaced.
- If the valve will not open, make sure normal gas pressure is available at the valve, the bleed line is unobstructed, and power is available at the terminals.

## XIII Motorized Main Automatic Valve

- Motorized Main On-Off Valves are available on special order burners.
- When the actuator is energized, hydraulic fluid is pumped from a reservoir to a metal bellows. The bellows transfers the resulting pressure through the drive stem to open the valve.

- MPG burners may feature a redundant solenoid gas safety valve. This valve is an On-Off (2 position) valve.
- When the valve operator is electrically energized, a plunger lifts the valve disk off the valve seat, allowing gas to flow. When the current is broken the valve closes. It will normally require no service. If the operator malfunctions or the valve leaks replace the entire valve. After replacement check for leakage.

## XIV *Redundant Solenoid Gas Safety Valve*

**⚠ WARNING: Explosion hazard. Do not use this device if it gets wet. It can malfunction and cause serious injury or death. Replace any device that has been wet.**

## XV *Flame Safeguard*

- Standard MPG burners are equipped with either a Honeywell RM7895 or Siemens LME71 microprocessor based burner control employing a flame rectification system of flame detection. Burner construction for special codes and/or insurance requirements such as Factory Mutual or Industrial Risk Insurers (GAP) may require alternate controls. Refer to Section XVI **Special Equipment**. A safe start and run control sequence is provided with instantaneous response to presence or loss of flame signal. Flame failure response time is 3 seconds. Pilot Flame Establishing Period (PFEP) is field selectable from 4 or 10 seconds. The RM7895 features a pre-purge time (30-seconds for On-Off, 90-seconds for 2-Step or Modulating burners) and a plug-in amplifier. An airflow circuit is also field selectable to allow either lockout or recycle upon loss of airflow. Five LEDs (light emitting diodes) are provided to display sequence information. Refer to the control literature for detailed operating information, configuration requirements, testing and service. On the Siemens LME71, sequence information is displayed on the LED Display.

### **INITIATE (“POWER” LED is lit).**

▪ The RM7895 and the LME71 enters the **INITIATE** sequence when it is powered. The **INITIATE** sequence lasts for ten seconds unless the voltage or frequency tolerances are not met (refer to Honeywell RM7895 or the Siemens LME71 literature for criteria). When tolerances are met, the **INITIATE** sequence will restart. If the condition is not corrected and the hold condition exists for four minutes, the RM7895 and the LME71 will lock-out. Causes for hold conditions in the **INITIATE** sequence are in the Honeywell RM7895 and the Siemens LME71 literature.

### **STANDBY (“POWER” LED is lit).**

▪ The RM7895 and the LME71 will be idle in this state of sequencing. When the burner switch, limits, operating limit controls and all microprocessor monitored circuits are in the correct state for the RM7895 or LME71 to continue, sequencing will advance **to pre-purge**.

### **PRE-PURGE (“POWER” LED is lit).**

- The RM7895 and LME71 in this application features a pre-purge time of 30-seconds for On-Off, 90-seconds for 2-Step or Modulating burners.
- Once the **STANDBY** sequence has a “**CALL FOR HEAT**” input, normal start-up pre-purge will be initiated.
  - A. The blower motor is powered to start the pre-purge sequence.
  - B. The airflow interlock switch must close in ten seconds of pre-purge or within the specified purge card timing. Otherwise a recycle to the beginning of pre-purge or lockout will occur, depending on how the airflow switch selectable jumper is configured. Refer to Honeywell RM7895 or Siemens LME71 literature for configuration requirements.

### **IGNITION TRIAL**

1. PILOT FLAME ESTABLISHING PERIOD (PFEP)
  - A. The pilot valve and spark generator are energized.
  - B. Flame must be proven by the end of the 4 or 10-second PFEP to allow the sequence to continue. If flame is not proven by the end of PFEP, a safety shutdown occurs.
2. MAIN FLAME ESTABLISHING PERIOD (MFEP)

- After the ignition trials, and with the presence of flame, the main valve is energized. (“MAIN” LED will be lit.) If a flame-out occurs, the RM7895 will lockout or recycle within 3-seconds, depending on “jumper” configuration. Refer to Honeywell or the Siemens literature for proper configuration.

# Part 1 Installation

## XV *Flame Safeguard Continued*

### **RUN**

▪ The RM7895 and the LME71 will now be in **RUN** mode and will remain in run mode until the controller input opens, indicating that the call for heat has been satisfied or a limit has opened. Once this occurs the RM7895 or the LME71 will sequence back to the **STANDBY** mode.

- Notes:**
1. During **STANDBY** and during RM7895 or the LME71 sequencing the "POWER" LED will blink every four seconds. This is normal.
  2. The "ALARM" LED will be lit in the event of any flame failure.
  3. To maintain proper operation of this device it **MUST** be electrically grounded. Refer to Honeywell RM7895 or the Siemens LME71 literature for grounding requirements.

## XVI *Special Equipment (OEM Versions)*

▪ Special equipment, either factory or field installed, can cause variations in the procedures and descriptions given in this manual. Generally, any burner ordered with special factory installed equipment will be supplied with the appropriate wiring diagram and related instruction manuals from the special equipment manufacturer. Consult these manuals to identify any differences in construction, operation and testing. Field installed special equipment is the responsibility of the installing contractor.

▪ For example, when a high/low gas pressure switch is used, the high gas pressure setting must be higher than the maximum manifold pressure during initial start-up and the low pressure setting must be set below the normal minimum inlet pressure to prevent nuisance shutdowns during the start-up procedure.

▪ After the burner is started, the low pressure setting should be raised until the burner shuts off. Reduce the setting and set the low pressure switch to restart the burner. Reduce the high pressure setting until the burner shuts off. Then raise the setting slightly and reset the high pressure switch to restart the burner. Do not make the adjustments too close to trip points or nuisance shut downs may occur. Anytime the burner gas supply is shut off with the main manual valve, the low pressure switch will require resetting.

▪ If any doubt exists concerning burner operation when special equipment is involved, contact the installing contractor or MIDCO INTERNATIONAL INC..

## XVII *Initial Start Up Instructions 2-Stage and Full Modulating Burner*

**Note:** These Instructions are designed for experienced combustion contractors/ technicians.

- 1) Check the gas piping for leaks. If a leak is detected, it should be repaired.
- 2) Make sure that the burner main and pilot gas lines are both completely purged of air. Do not purge into the combustion chamber. Purge outside the building.
- 3) Make sure the burner power On-Off switch is OFF, manual main gas valve and manual pilot gas valves are closed and the motor is free to rotate.
- 4) Make the proper settings on all limit controls and set the operating controller (by others) to call for heat.
- 5) Loosen the linkage connecting rod at the ball joint (7/16" wrench) nearest to the motorized actuator and the U clamp (5/16" deep socket) of the motorized actuator, and set:
  - a. air shutter at minimum opening position
  - b. gas flow control valve at 2 O'clock
  - c. both crank arms at 7 O'clock

**Note:** Linkage connecting rod should be parallel to blower scroll housing face.

- 6) Turn the burner power On-Off switch to ON and allow the motor to run through the pre-purge and ignition cycle. Check the blower wheel for proper rotation. Viewing from the blower inlet screen, rotation should be counter-clockwise. After approximately 90 seconds, the flame safe guard will lock out, stopping the motor.
- 7) Open the pilot manual gas valve leaving the main manual gas valve closed. Reset the flame safe guard. Motor will start. When the pre-purge period (90 seconds) has completed, the flame safe guard will energize the pilot solenoid valve and the spark generator. The pilot should be ignited and the flame rod or UV scanner senses the pilot flame. Adjust the pilot gas pressure to reach the strongest and most stable pilot flame signal. See Table 8 for preliminary pilot gas pressure settings. Test several times for pilot ignition, stability and flame sensing signal.

## *XVII Initial Start Up Instructions 2-Stage and Full Modulating Burner Continued*

- 8) Measure the main gas differential pressure by installing a digital manometer. One gas pressure tap should be installed in the downstream port of the downstream automatic main gas safety shutoff valve. The second gas pressure tap should be installed in the manifold test tap that is located just upstream of the gas flow control valve. See Table 7 for initial differential manifold gas pressure & air shutter settings.
- 9) Slowly open the main manual gas valve with the main valves energized and watch through the peep sight glass located on the back of the pilot drawer assembly to make sure that the main flame ignites.
- 10) Check the flue gas readings with a combustion gas analyzer. Slowly and manually adjust the gas flow control valve and/or air shutter to achieve the correct burner low fire firing rate and proper preliminary flue gas readings (approximately 4 - 5% O<sub>2</sub> and approximately 9 - 9 ½% CO<sub>2</sub>).
- 11) Slowly and manually adjust the gas flow control valve and/or air shutter to achieve the correct burner high fire firing rate and proper preliminary flue gas readings (approximately 4 - 5% O<sub>2</sub> and approximately 9 - 9 ½% CO<sub>2</sub>). Tighten the linkage connecting rod at the ball joint (7/16" wrench) nearest to the motorized actuator.
- 12) Check the flue gas readings with a combustion gas analyzer. Adjust the regulator of the main gas combination valve or the independent main gas pressure regulator and/or the air shutter to achieve the correct burner high fire firing rate and proper flue gas readings (approximately 4 - 5% O<sub>2</sub> and approximately 9½ - 10% CO<sub>2</sub>).

**Note:** For a full modulating burner, check the burner combustion performance at mid range firing rate and adjust as necessary.

- 13) Turn the burner power On-Off switch to OFF. Manually move the gas flow control valve, connecting rod and air shutter to the low fire position. Tighten the U clamp of the motorized actuator. Move the adjustable stop block of the motorized actuator to the 3 O'clock position and lock it in place. At the Midco control cabinet terminal strips, disconnect the signal input wires from the remote temperature controller. Place a temporary jumper from terminal M2 to M3 (this simulates a call for high fire heat).

**Note:** Circuit from terminal strip 5 to 6 must be closed in order for the burner to fire.

- 14) Turn the burner power On-Off switch to ON. The burner should start and sequence as follows:
  - a. 10 second initiation
  - b. 90 second pre-purge period
  - c. Pilot ignition, flame proving
  - d. Main flame ignition, low fire start
  - e. Main flame, high fire operation
- 15) If the measured high fire firing rate is less (more) than the desired value, turn the burner power On-Off switch to OFF, move the adjustable stop block of the motorized actuator up (down) and try again until reaching the desired high fire firing rate.
- 16) Cycle the burner several times and verify:
  - a. 10 second initiation period
  - b. 90 second purge period
  - c. pilot ignition
  - b. pilot flame sensing signal is strong and stable
  - c. main gas ignition
  - d. low fire firing rate
  - e. high fire firing rate
  - f. combustion gas analyzer readings

Adjust if necessary.
- 17) Turn the burner power On-Off switch to OFF and remove the temporary jumper that was placed from terminal M2 to M3. Remove the digital manometer and connectors and replace the plugs on the main gas valve and the main manifold test tap. Reconnect the signal input wires from the remote temperature controller..

# Trouble Chart

Make sure the thermostat and operating controls are calling for heat. Defective wiring or loose connections can simulate the component defects outlined below. Check associated wiring before replacing a component. ELECTRICAL AND FLAME CHECKS MUST BE MADE IN THE ORDER LISTED.

## ***I Motor Fails***

- A. No power to flame safeguard
- B. Flame safeguard locked out
- C. Defective flame safeguard
- D. Defective motor relay
- E. Motor overload "out"

## ***II Motor Fails to Start, Flame, Safeguard Energized***

- A. Motor overload "out"
- B. Defective motor
- C. Defective flame safeguard

## ***III Motor Runs Continuously, No Lighting Attempt***

- A. Defective air switch
- B. No air pressure at air switch
- C. Defective purge timer (if equipped)
- D. Defective flame safeguard

## ***IV Pilot Does Not Light, Flame Safeguard Locks Out***

- A. No pilot gas
- B. Low pilot gas pressure
- C. Defective pilot gas regulator
- D. Mis-adjusted pilot regulator
- E. Blocked pilot regulator vent
- F. Defective pilot solenoid valve
- G. Defective spark electrode
- H. Mis-adjusted spark electrode
- I. Defective spark cable
- J. Defective spark generator
- K. Clogged or incorrect pilot orifice
- L. Air orifice missing
- M. Clogged pilot air tube
- N. Defective flame safeguard

## ***V Pilot Lights, Flame Safeguard Locks Out***

- A. Poor flame signal
- B. Poor pilot flame
- C. Misadjusted pilot regulator
- D. Low gas pressure
- E. Misadjusted air shutter
- F. Defective flame rod wire
- G. Defective or mis-adjusted flame rod
- H. Defective amplifier (if equipped)
- I. Defective flame safeguard

## ***VI Pilot Lights, No Lockout on Flame Safeguard, No Main Gas***

- A. Low gas pressure
- B. Mis-adjusted main regulator
- C. Blocked regulator vent
- D. Defective main regulator
- E. No power at main valve(s)
- F. Blocked main valve bleed line (if equipped)
- G. Defective main valve(s)
- H. Closed test cock
- I. Defective flame safeguard

# Trouble Chart

- A. Poor pilot
- B. Pilot gas pressure drops severely when main gas valve opens
- C. Mis-adjusted pilot regulator

- A. Low gas pressure
- B. Defective main regulator
- C. Mis-adjusted main regulator
- D. Too much air
- E. Partially closed test cock

- A. High gas pressure
- B. Defective main regulator
- C. Mis-adjusted main regulator
- D. Too little air
- E. Dirty blower wheel

- A. Defective valve(s)
- B. Defective valve actuator
- C. Dirty valve seat

- A. Low voltage
- B. Defective motor
- C. High ambient temperature
- D. Dirty blower wheel

- A. See IV above
- B. See V above
- C. See VI above

**Note:** Some of the probable causes listed above apply only to certain models as indicated, therefore some may not apply to your particular case.

**VII Main Flame Lights, But Goes out, Pilot Re-lights**

**VIII Short Main Flame**

**IX Long Hazy Flame**

**X Main Valve(s) Fail to Shut Off or Leaks**

**XI Motor Overload Frequently Trips Out**

**XII Flame Safeguard Needs Frequent Re-setting**

# Unipower MPG Series Installation & Service Manual

---

